

Analog IO

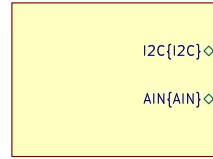

File: analog.kicad_sch

Teensy

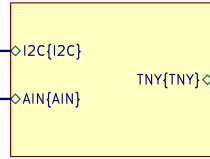

File: teensy.kicad_sch

Fan Out

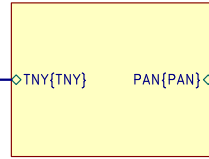

File: fan_out.kicad_sch

Panels

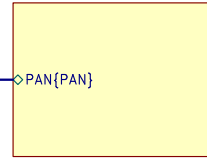

File: panels.kicad_sch

Power

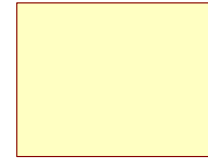

File: power.kicad_sch

Mount Holes



File: holes.kicad_sch

IO Rodeo for Reiser Lab @ Janelia | HHMI

Sheet: /

File: arena_10_of_10_v1r1.kicad_sch

Title: G6 Teensy 10-10 Arena

Size: A4 Date: 2026-04-27

Rev: v1.1.6

KiCad E.D.A. 9.0.8

Id: 1/63

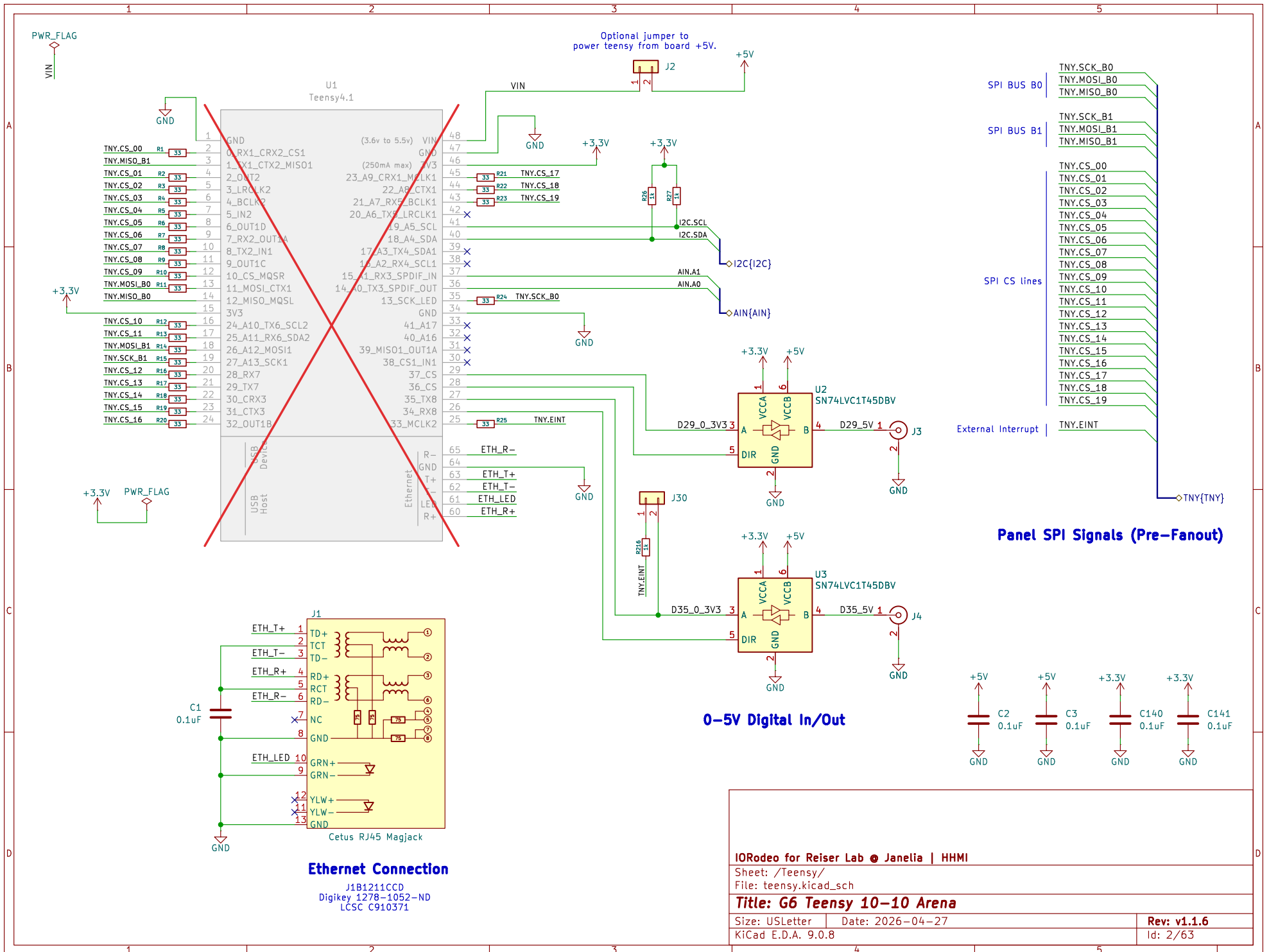

IORodeo for Reiser Lab © Janelia | HHMI

Sheet: /Teensy/
File: teensy.kicad_sch

Title: G6 Teensy 10-10 Arena

Size: USLetter | Date: 2026-04-27
KiCad E.D.A. 9.0.8

Rev: v1.1.6
Id: 2/63

Singals to/from Teensy

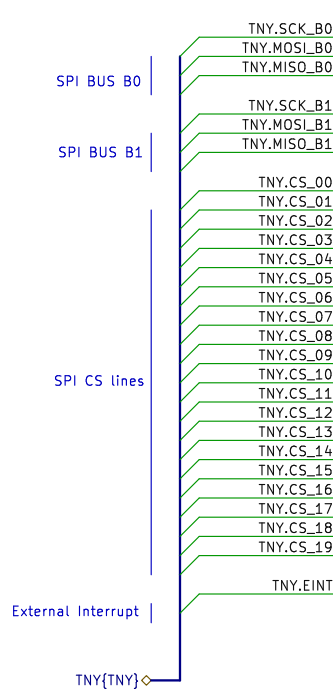

Pre-fanout signals

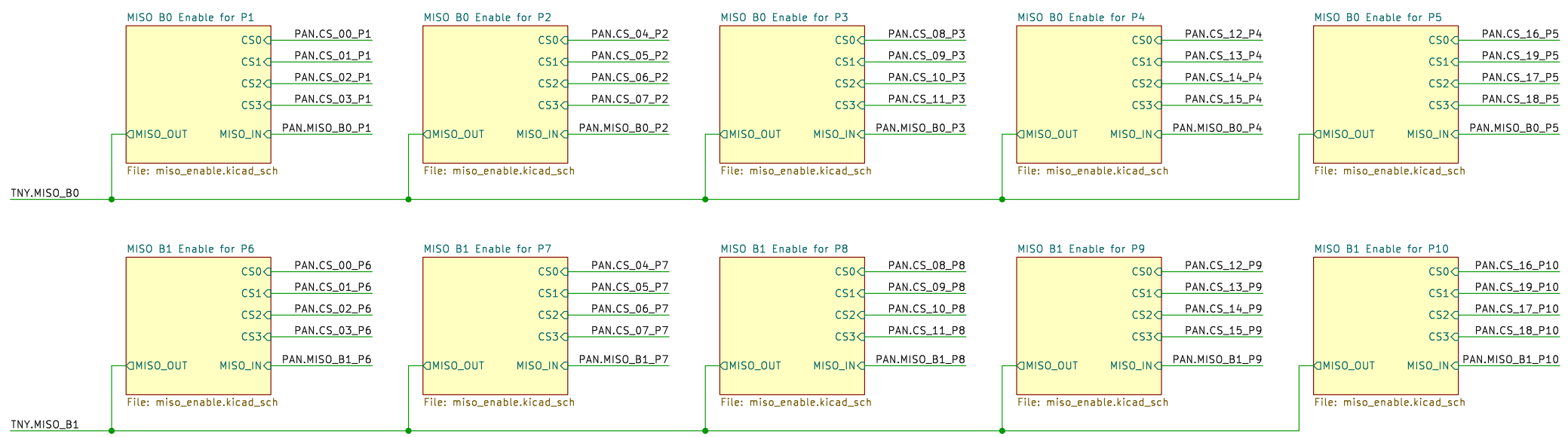
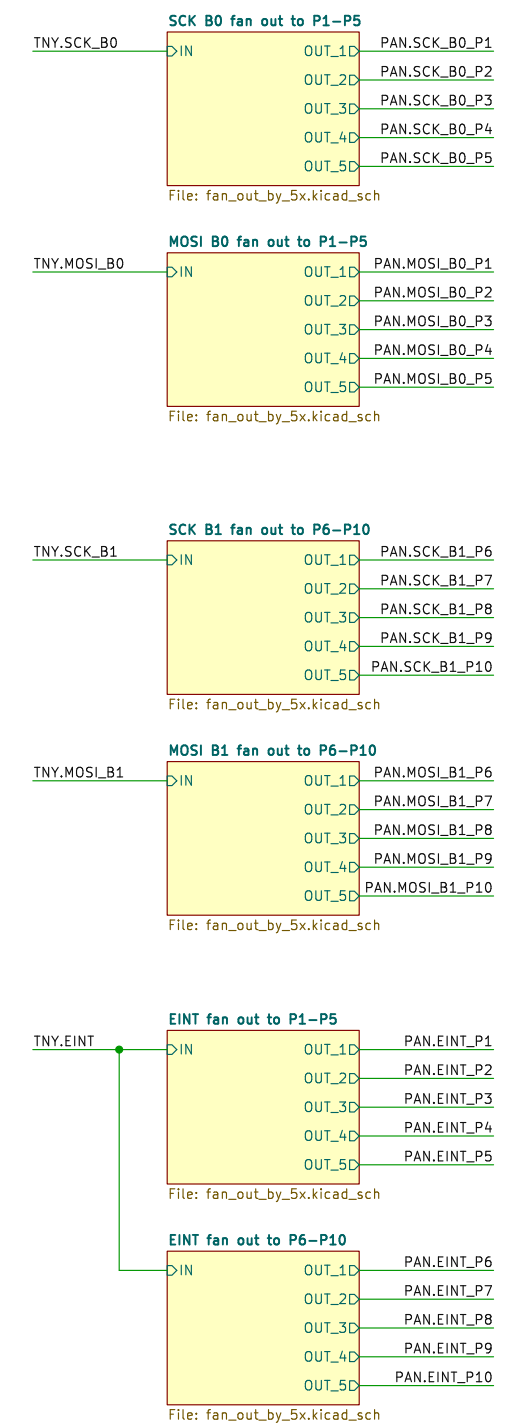

Singals to/from Panels

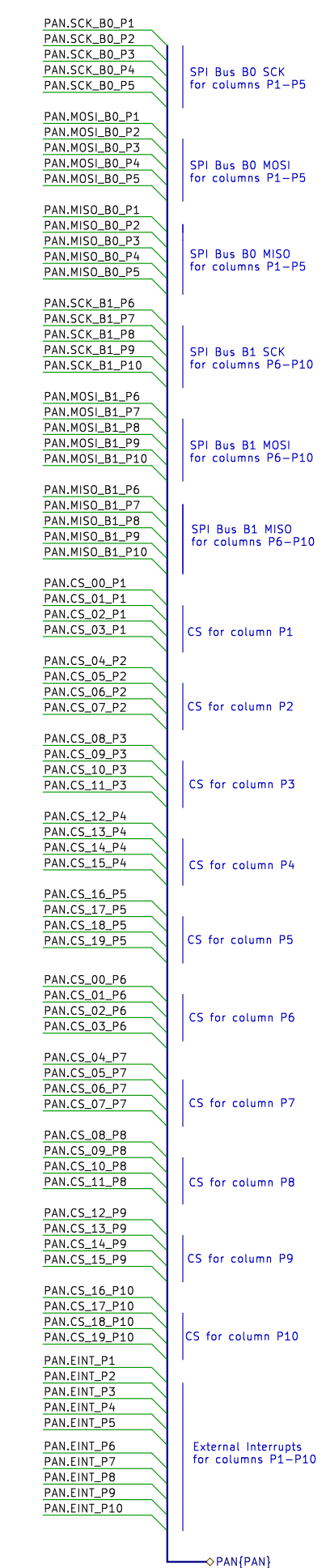

Post-Fanout Signals

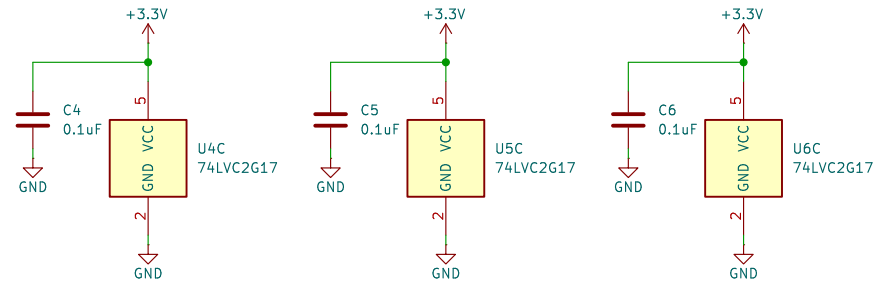
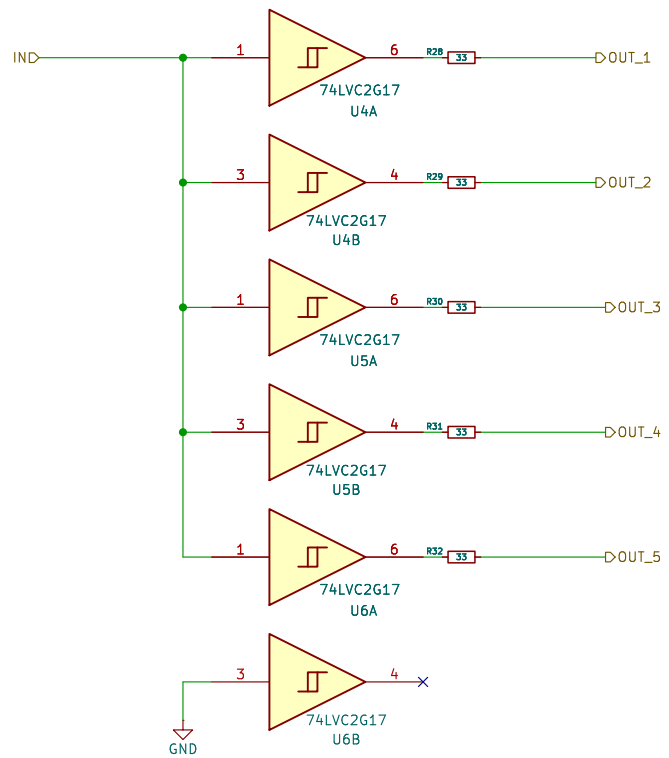

IOReode for Reiser Lab @ Janelia | HHMI

Sheet: /Fan Out/SCK B0 fan out to P1-P5/
File: fan_out_by_5x.kicad_sch

Title: G6 Teensy 10-10 Arena

Size: A4 Date: 2026-04-27

KiCad E.D.A. 9.0.8

Rev: v1.1.6

Id: 4/63

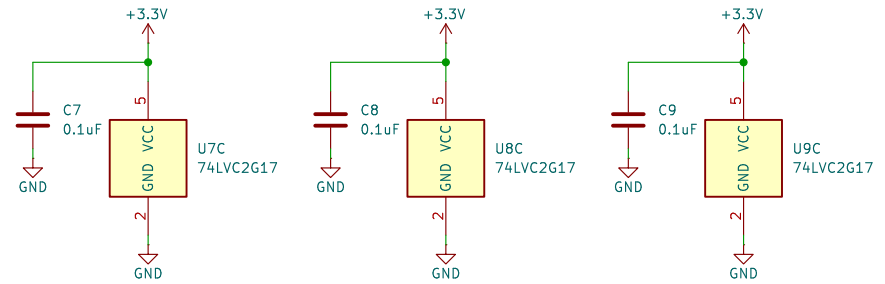
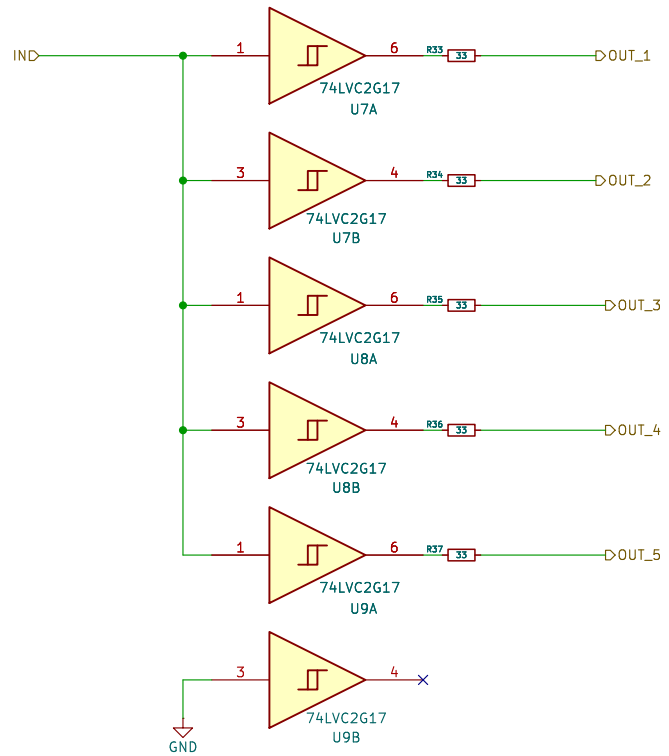

IOReode for Reiser Lab @ Janelia | HHMI

Sheet: /Fan Out/MOSI B0 fan out to P1-P5/
 File: fan_out_by_5x.kicad_sch

Title: G6 Teensy 10-10 Arena

Size: A4 Date: 2026-04-27

KiCad E.D.A. 9.0.8

Rev: v1.1.6

Id: 5/63

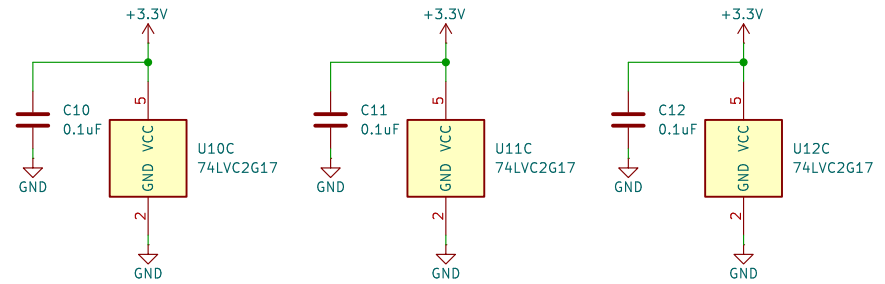
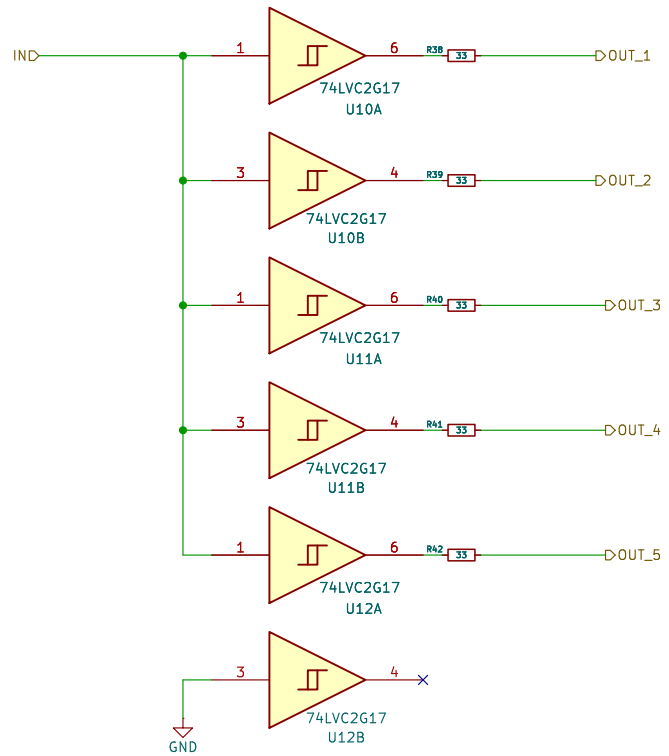

IORodeo for Reiser Lab @ Janelia | HHMI

Sheet: /Fan Out/SCK B1 fan out to P6-P10/
 File: fan_out_by_5x.kicad_sch

Title: G6 Teensy 10-10 Arena

Size: A4 Date: 2026-04-27

KiCad E.D.A. 9.0.8

Rev: v1.1.6

Id: 6/63

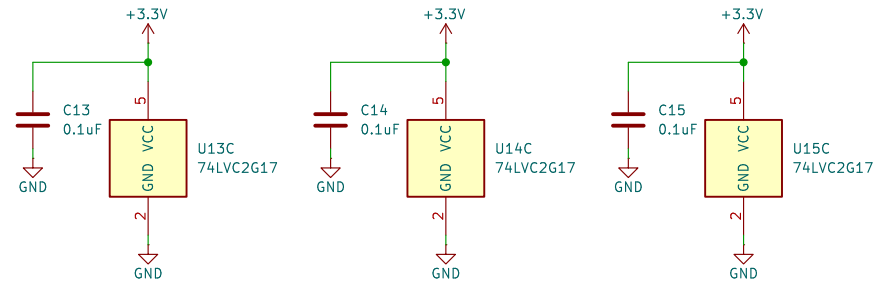
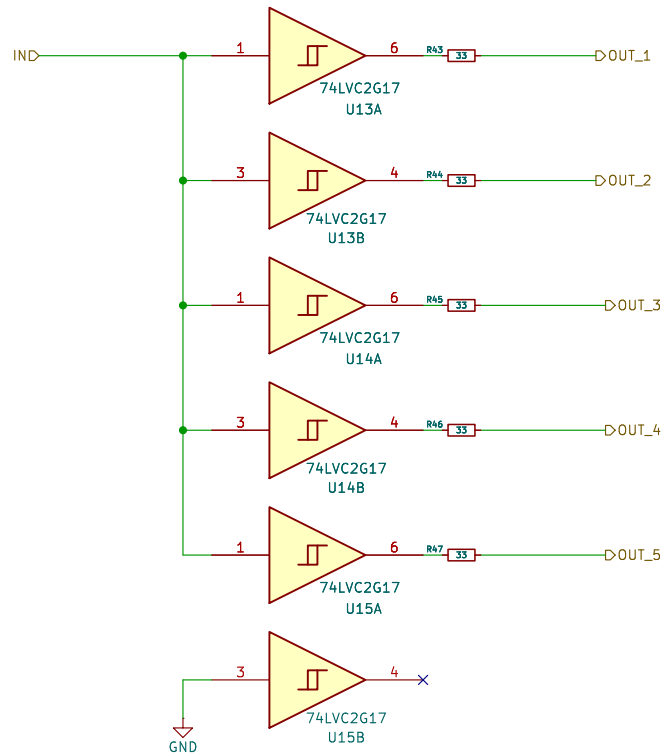

IORodeo for Reiser Lab @ Janelia | HHMI

Sheet: /Fan Out/MOSI B1 fan out to P6-P10/
 File: fan_out_by_5x.kicad_sch

Title: G6 Teensy 10-10 Arena

Size: A4 Date: 2026-04-27

KiCad E.D.A. 9.0.8

Rev: v1.1.6

Id: 7/63

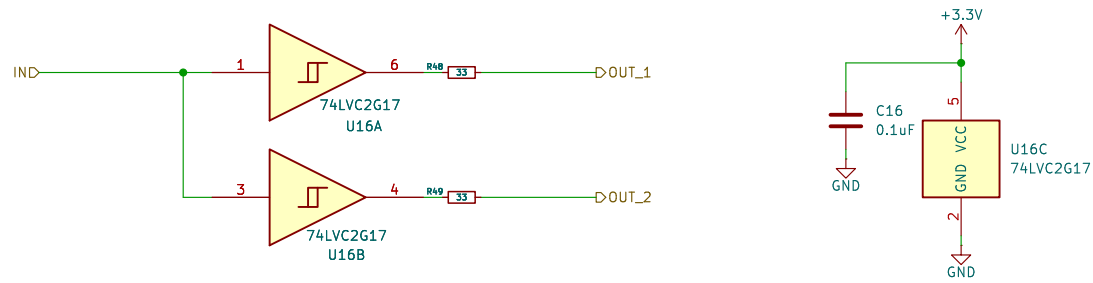

IORodeo for Reiser Lab @ Janelia | HHMI

Sheet: /Fan Out/CS_00 fan out to P1, P6/
 File: fan_out_by_2x.kicad_sch

Title: G6 Teensy 10-10 Arena

Size: A4 Date: 2026-04-27

Rev: v1.1.6

KiCad E.D.A. 9.0.8

Id: 8/63

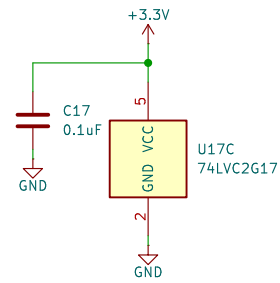
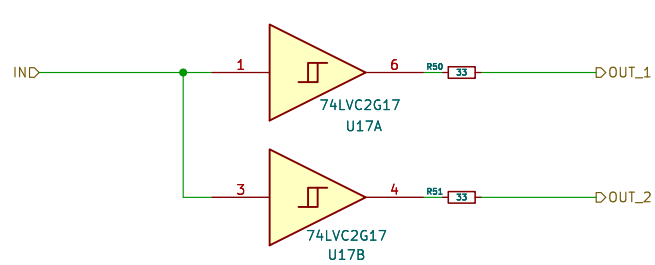

IORodeo for Reiser Lab @ Janelia | HHMI

Sheet: /Fan Out/CS_01 fan out to P1, P6/

File: fan_out_by_2x.kicad_sch

Title: G6 Teensy 10-10 Arena

Size: A4

Date: 2026-04-27

Rev: v1.1.6

KiCad E.D.A. 9.0.8

Id: 9/63

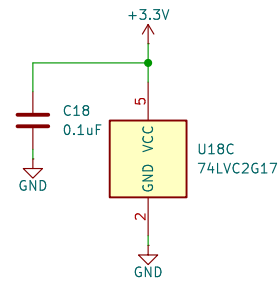
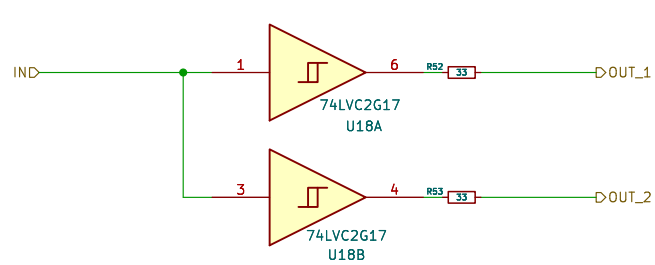

IORodeo for Reiser Lab @ Janelia | HHMI

Sheet: /Fan Out/CS_02 fan out to P1, P6/
File: fan_out_by_2x.kicad_sch

Title: G6 Teensy 10-10 Arena

Size: A4 Date: 2026-04-27

Rev: v1.1.6

KiCad E.D.A. 9.0.8

Id: 10/63

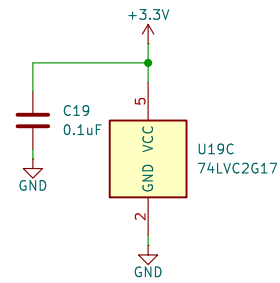
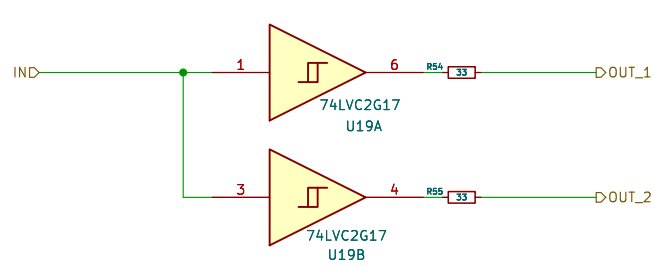

IORodeo for Reiser Lab @ Janelia | HHMI

Sheet: /Fan Out/CS_03 Fan Out to P1, P6/
File: fan_out_by_2x.kicad_sch

Title: G6 Teensy 10-10 Arena

Size: A4 Date: 2026-04-27

Rev: v1.1.6

KiCad E.D.A. 9.0.8

Id: 11/63

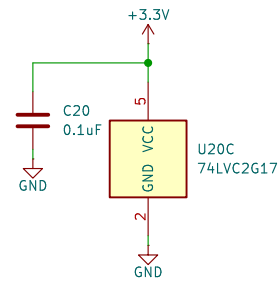
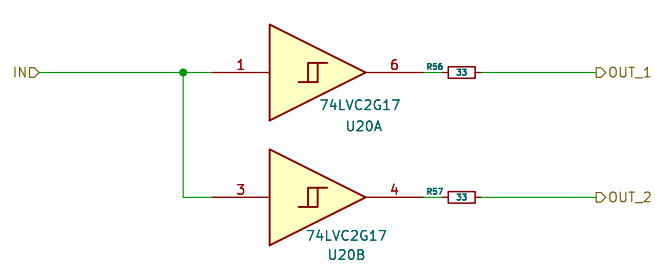

IORodeo for Reiser Lab @ Janelia | HHMI

Sheet: /Fan Out/CS_04 fan out to P2, P7/

File: fan_out_by_2x.kicad_sch

Title: G6 Teensy 10-10 Arena

Size: A4

Date: 2026-04-27

Rev: v1.1.6

KiCad E.D.A. 9.0.8

Id: 12/63

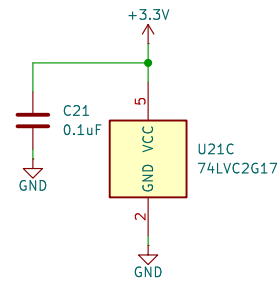
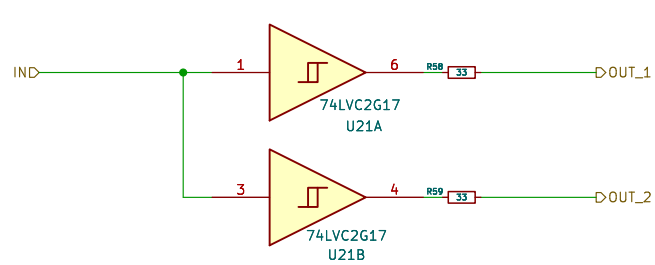

IORodeo for Reiser Lab @ Janelia | HHMI

Sheet: /Fan Out/CS_05 fan out to P2, P7/

File: fan_out_by_2x.kicad_sch

Title: G6 Teensy 10-10 Arena

Size: A4

Date: 2026-04-27

Rev: v1.1.6

KiCad E.D.A. 9.0.8

Id: 13/63

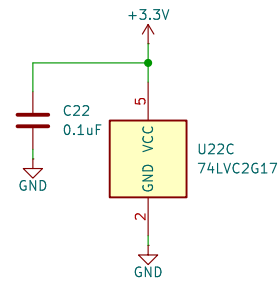
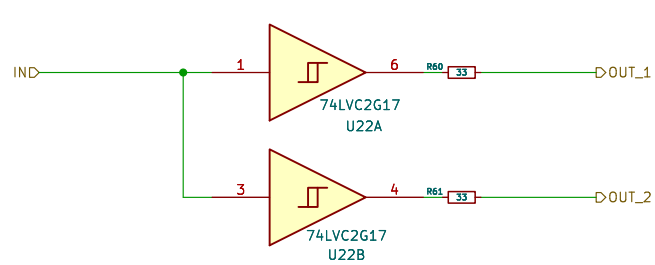

IORodeo for Reiser Lab @ Janelia | HHMI

Sheet: /Fan Out/CS_06 fan out to P2, P7/

File: fan_out_by_2x.kicad_sch

Title: G6 Teensy 10-10 Arena

Size: A4

Date: 2026-04-27

Rev: v1.1.6

KiCad E.D.A. 9.0.8

Id: 14/63

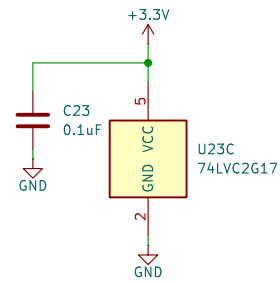
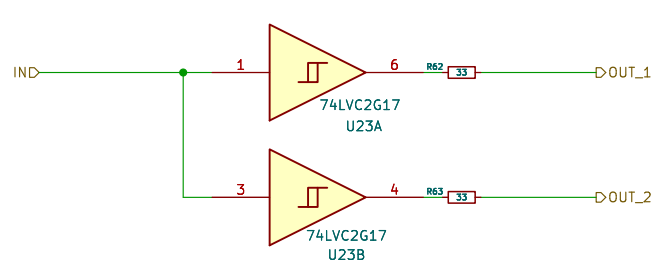

IORodeo for Reiser Lab @ Janelia | HHMI

Sheet: /Fan Out/CS_07 fan out to P2, P7/
File: fan_out_by_2x.kicad_sch

Title: G6 Teensy 10-10 Arena

Size: A4 Date: 2026-04-27

Rev: v1.1.6

KiCad E.D.A. 9.0.8

Id: 15/63

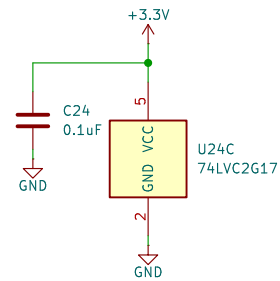
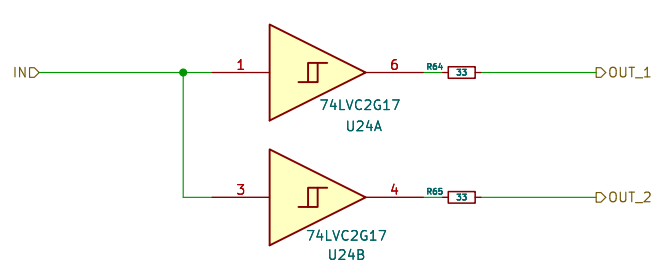

IORodeo for Reiser Lab @ Janelia | HHMI

Sheet: /Fan Out/CS_08 fan out to P3, P8/
File: fan_out_by_2x.kicad_sch

Title: G6 Teensy 10-10 Arena

Size: A4 Date: 2026-04-27

Rev: v1.1.6

KiCad E.D.A. 9.0.8

Id: 16/63

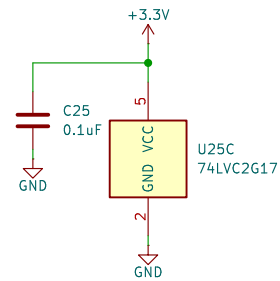
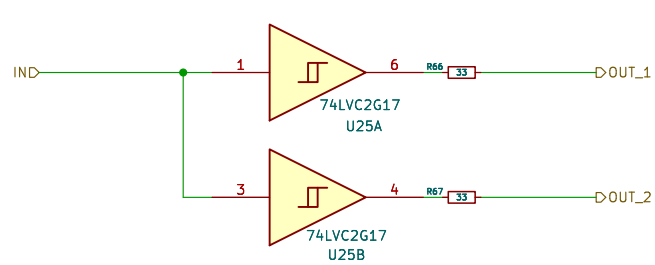

IORodeo for Reiser Lab @ Janelia | HHMI

Sheet: /Fan Out/CS_09 fan out to P3, P8/
File: fan_out_by_2x.kicad_sch

Title: G6 Teensy 10-10 Arena

Size: A4 Date: 2026-04-27

Rev: v1.1.6

KiCad E.D.A. 9.0.8

Id: 17/63

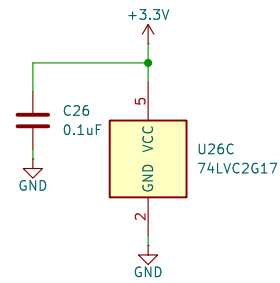
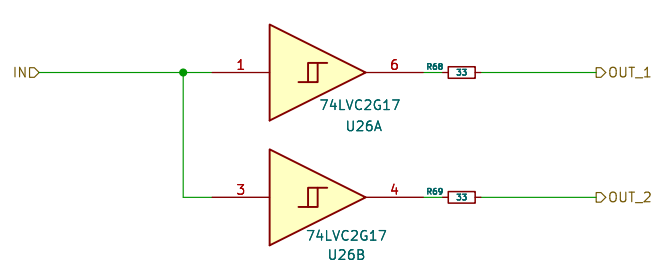

IORodeo for Reiser Lab @ Janelia | HHMI

Sheet: /Fan Out/CS_10 fan out to P3, P8/
 File: fan_out_by_2x.kicad_sch

Title: G6 Teensy 10-10 Arena

Size: A4 Date: 2026-04-27

Rev: v1.1.6

KiCad E.D.A. 9.0.8

Id: 18/63

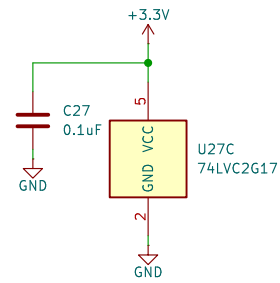
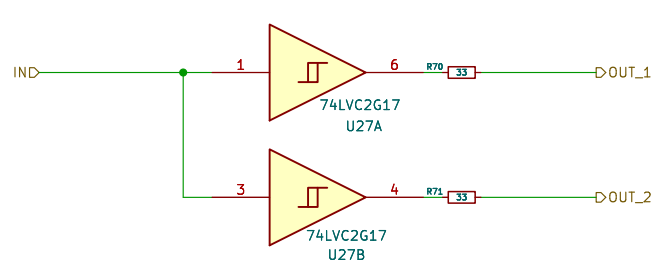

IORodeo for Reiser Lab @ Janelia | HHMI

Sheet: /Fan Out/CS_11 fan out to P3, P8/
File: fan_out_by_2x.kicad_sch

Title: G6 Teensy 10-10 Arena

Size: A4 Date: 2026-04-27

Rev: v1.1.6

KiCad E.D.A. 9.0.8

Id: 19/63

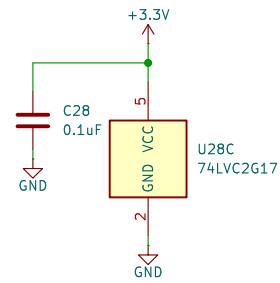
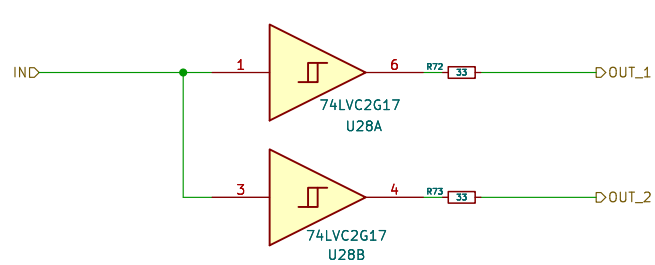

IORodeo for Reiser Lab @ Janelia | HHMI

Sheet: /Fan Out/CS_12 fan out to P4, P9/
 File: fan_out_by_2x.kicad_sch

Title: G6 Teensy 10-10 Arena

Size: A4 Date: 2026-04-27

Rev: v1.1.6

KiCad E.D.A. 9.0.8

Id: 20/63

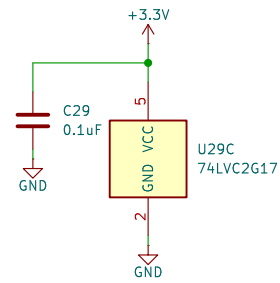
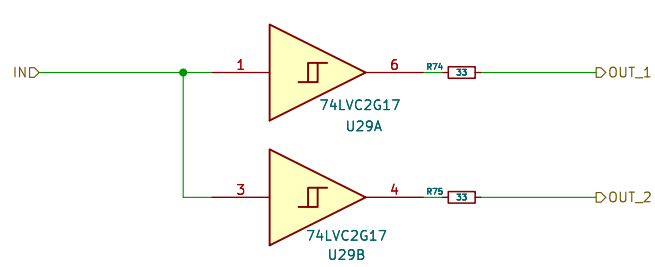

IORodeo for Reiser Lab @ Janelia | HHMI

Sheet: /Fan Out/CS_13 fan out to P4, P9/
File: fan_out_by_2x.kicad_sch

Title: G6 Teensy 10-10 Arena

Size: A4 Date: 2026-04-27

Rev: v1.1.6

KiCad E.D.A. 9.0.8

Id: 21/63

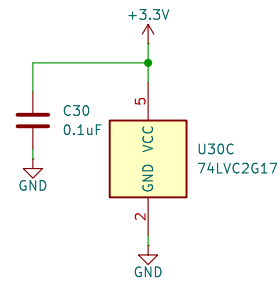
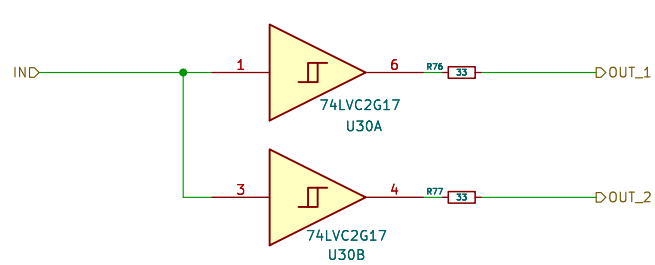

IORodeo for Reiser Lab @ Janelia | HHMI

Sheet: /Fan Out/CS_14 fan out to P4, P9/
 File: fan_out_by_2x.kicad_sch

Title: G6 Teensy 10-10 Arena

Size: A4 Date: 2026-04-27

Rev: v1.1.6

KiCad E.D.A. 9.0.8

Id: 22/63

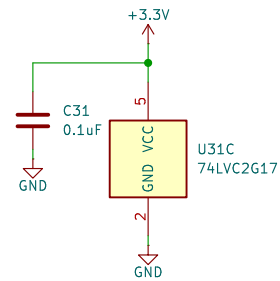
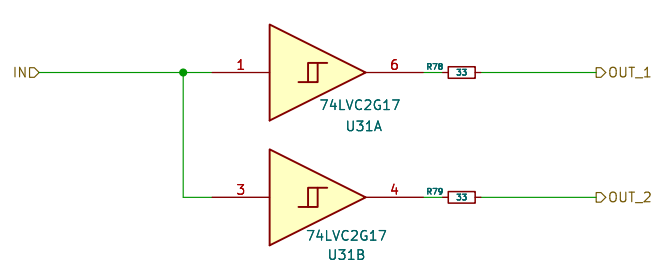

IORodeo for Reiser Lab @ Janelia | HHMI

Sheet: /Fan Out/CS_15 fan out to P4, P9/
File: fan_out_by_2x.kicad_sch

Title: G6 Teensy 10-10 Arena

Size: A4 Date: 2026-04-27

KiCad E.D.A. 9.0.8

Rev: v1.1.6

Id: 23/63

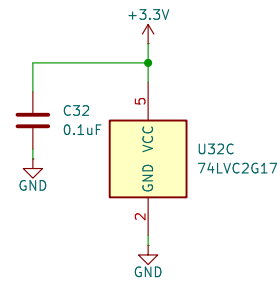
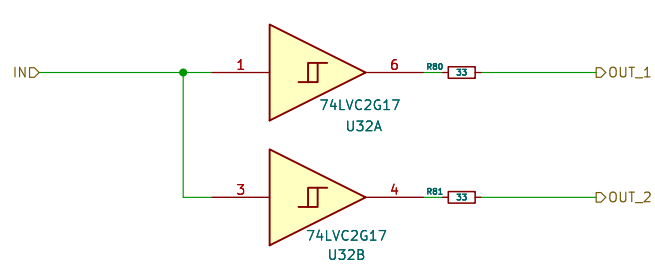

IORodeo for Reiser Lab @ Janelia | HHMI

Sheet: /Fan Out/CS_16 fan out to P5, P10/
File: fan_out_by_2x.kicad_sch

Title: G6 Teensy 10-10 Arena

Size: A4 Date: 2026-04-27

Rev: v1.1.6

KiCad E.D.A. 9.0.8

Id: 24/63

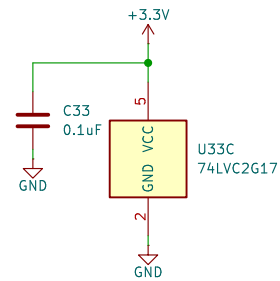
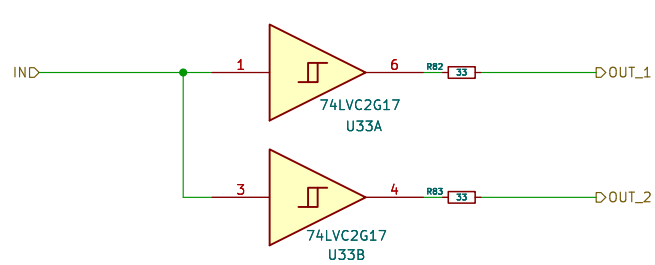

IORodeo for Reiser Lab @ Janelia | HHMI

Sheet: /Fan Out/CS_17 fan out to P5, P10/
File: fan_out_by_2x.kicad_sch

Title: G6 Teensy 10-10 Arena

Size: A4 Date: 2026-04-27

Rev: v1.1.6

KiCad E.D.A. 9.0.8

Id: 25/63

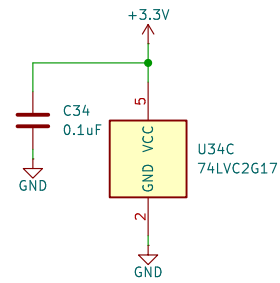
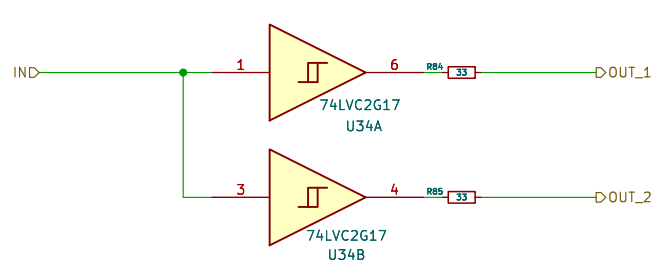

IORodeo for Reiser Lab @ Janelia | HHMI

Sheet: /Fan Out/CS_18 fan out to P5, P10/
File: fan_out_by_2x.kicad_sch

Title: G6 Teensy 10-10 Arena

Size: A4 Date: 2026-04-27

Rev: v1.1.6

KiCad E.D.A. 9.0.8

Id: 26/63

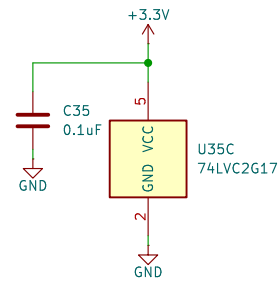
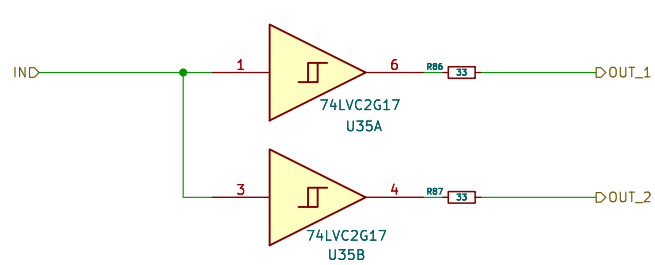

IORodeo for Reiser Lab @ Janelia | HHMI

Sheet: /Fan Out/CS_19 fan out to P5, P10/
File: fan_out_by_2x.kicad_sch

Title: G6 Teensy 10-10 Arena

Size: A4 Date: 2026-04-27

Rev: v1.1.6

KiCad E.D.A. 9.0.8

Id: 27/63

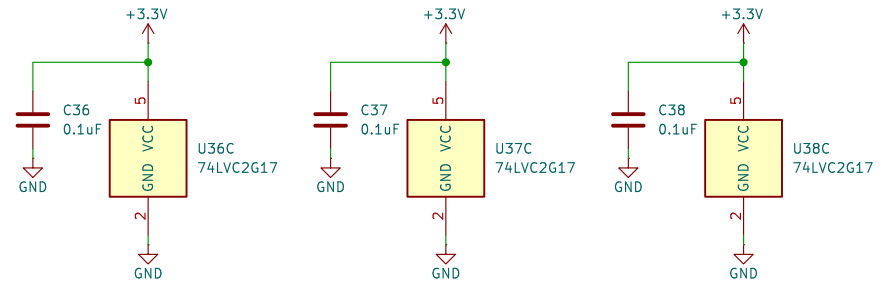
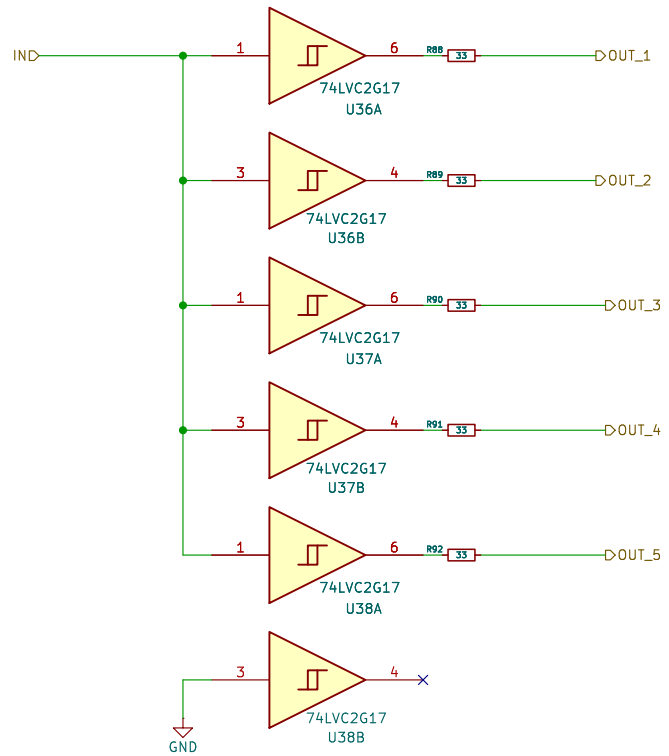

IORodeo for Reiser Lab @ Janelia | HHMI

Sheet: /Fan Out/EINT fan out to P6-P10/

File: fan_out_by_5x.kicad_sch

Title: G6 Teensy 10-10 Arena

Size: A4

Date: 2026-04-27

Rev: v1.1.6

KiCad E.D.A. 9.0.8

Id: 28/63

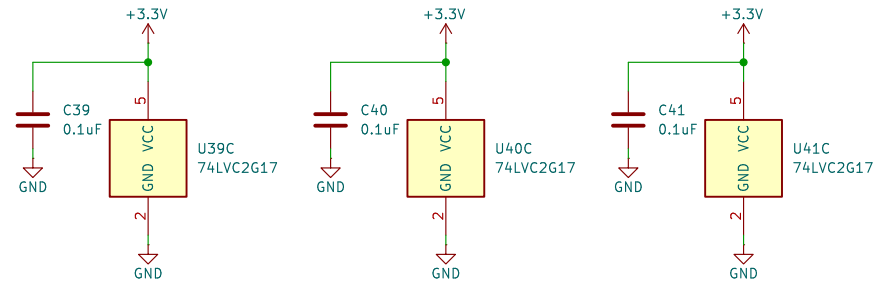
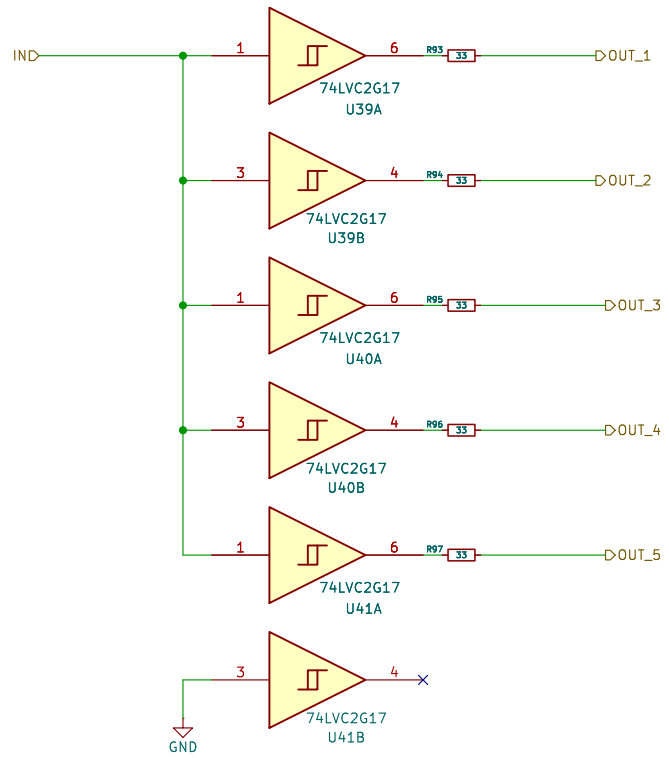

IORodeo for Reiser Lab @ Janelia | HHMI

Sheet: /Fan Out/EINT fan out to P1-P5/
File: fan_out_by_5x.kicad_sch

Title: G6 Teensy 10-10 Arena

Size: A4 Date: 2026-04-27

KiCad E.D.A. 9.0.8

Rev: v1.1.6

Id: 29/63

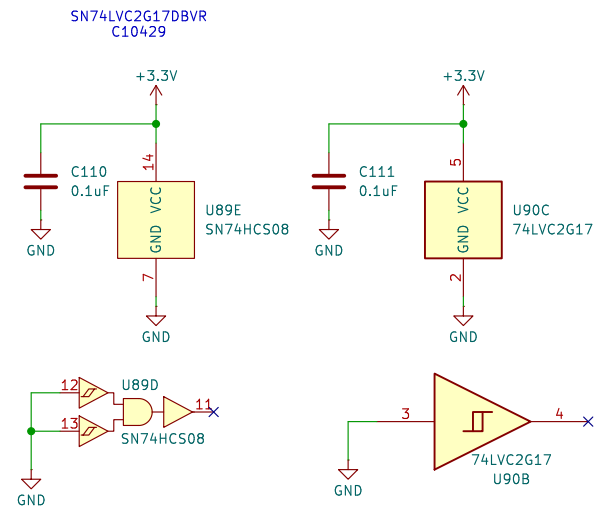
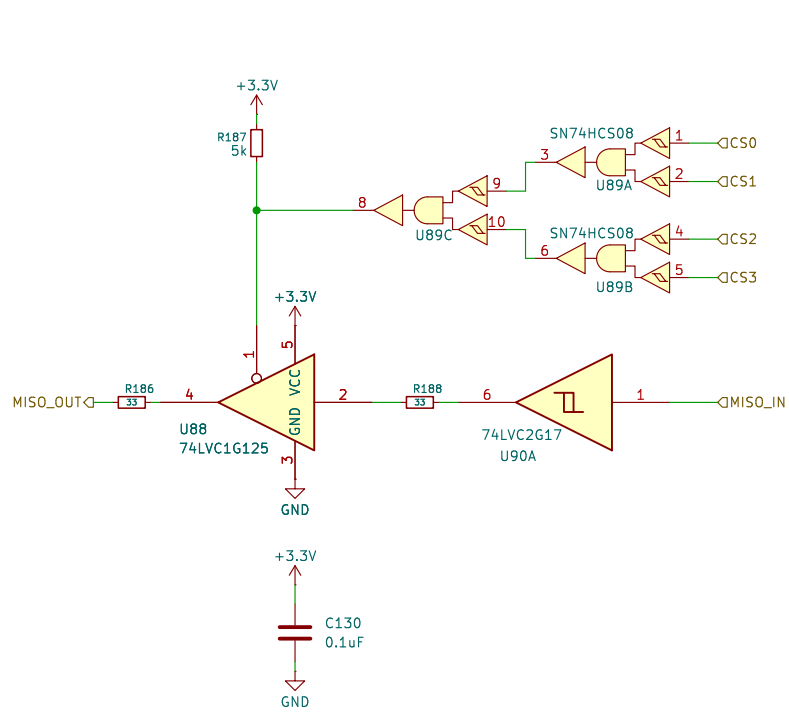

IORodeo for Reiser Lab @ Janelia | HHMI

Sheet: /Fan Out/MISO B0 Enable for P1/
 File: miso_enable.kicad_sch

Title: G6 Teensy 10-10 Arena

Size: A4 Date: 2026-04-27

KiCad E.D.A. 9.0.8

Rev: v1.1.6

Id: 54/63

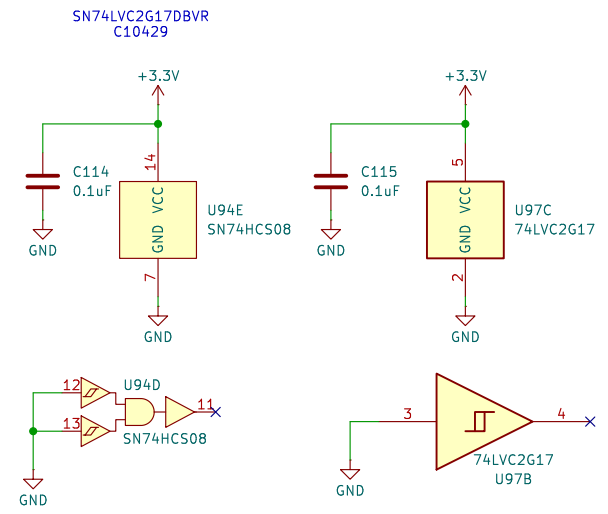
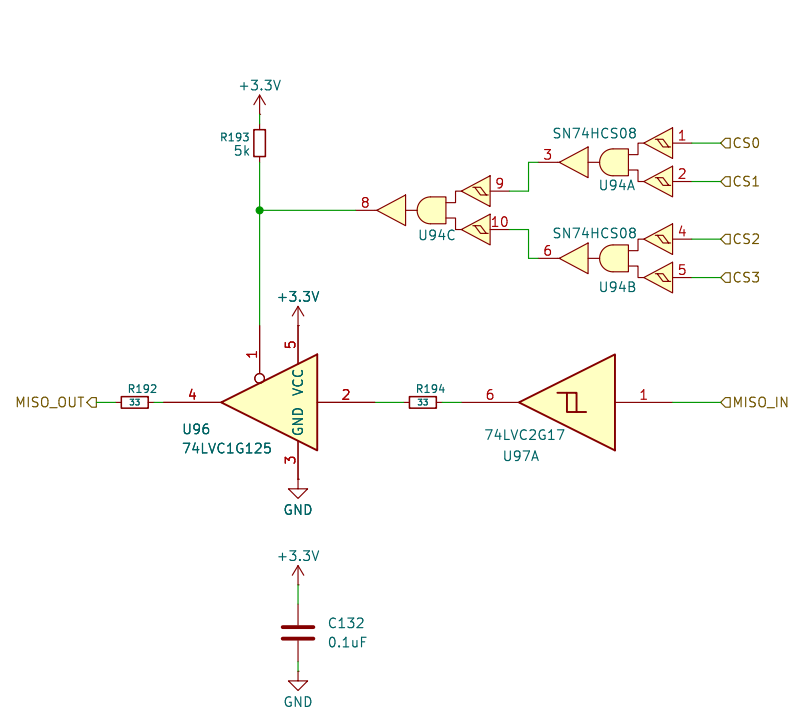

IORodeo for Reiser Lab @ Janelia HHMI	
Sheet: /Fan Out/MISO B0 Enable for P3/ File: miso_enable.kicad_sch	
Title: G6 Teensy 10-10 Arena	
Size: A4	Date: 2026-04-27
KiCad E.D.A. 9.0.8	Rev: v1.1.6 Id: 56/63

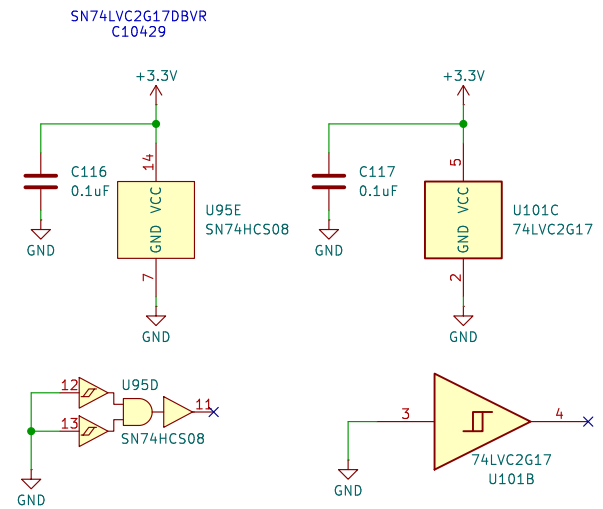
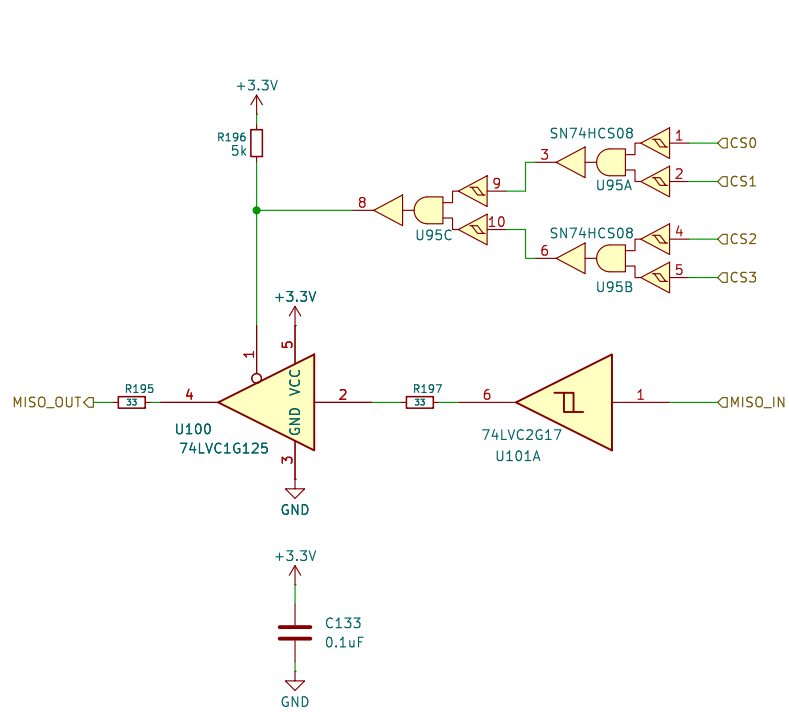

IORodeo for Reiser Lab @ Janelia | HHMI

Sheet: /Fan Out/MISO B0 Enable for P4/
File: miso_enable.kicad_sch

Title: G6 Teensy 10-10 Arena

Size: A4 Date: 2026-04-27

KiCad E.D.A. 9.0.8

Rev: v1.1.6

Id: 57/63

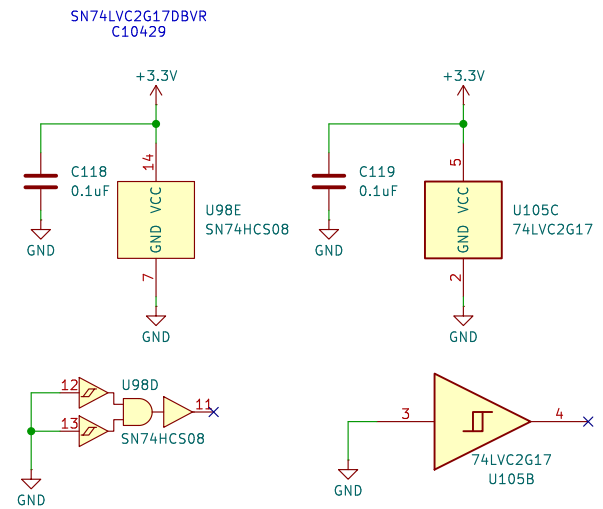
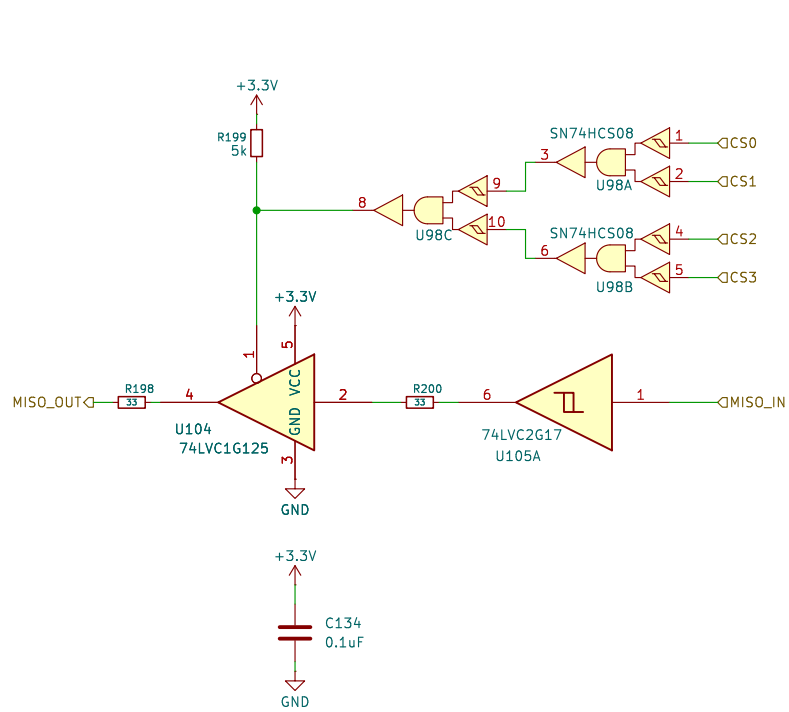

IORodeo for Reiser Lab @ Janelia | HHMI

Sheet: /Fan Out/MISO B0 Enable for P5/
 File: miso_enable.kicad_sch

Title: G6 Teensy 10-10 Arena

Size: A4 Date: 2026-04-27

KiCad E.D.A. 9.0.8

Rev: v1.1.6

Id: 58/63

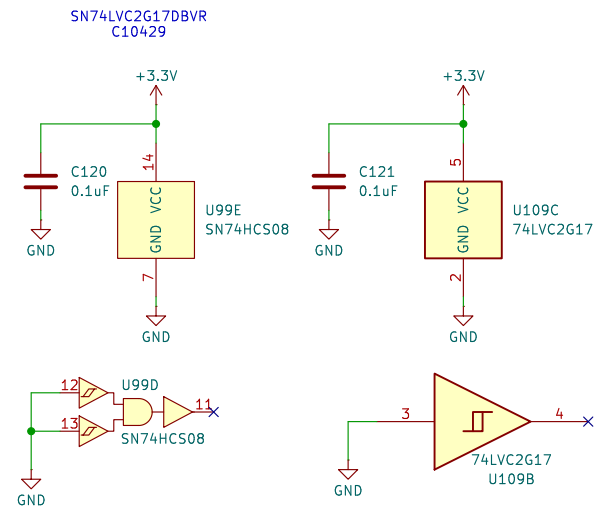
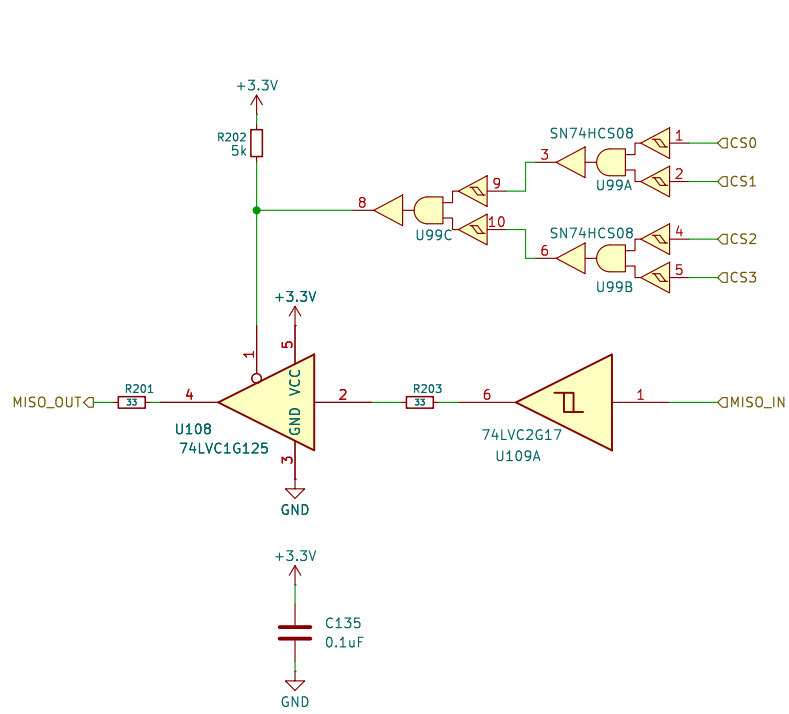

IORodeo for Reiser Lab @ Janelia | HHMI

Sheet: /Fan Out/MISO B1 Enable for P6/
File: miso_enable.kicad_sch

Title: G6 Teensy 10-10 Arena

Size: A4 Date: 2026-04-27

KiCad E.D.A. 9.0.8

Rev: v1.1.6

Id: 59/63

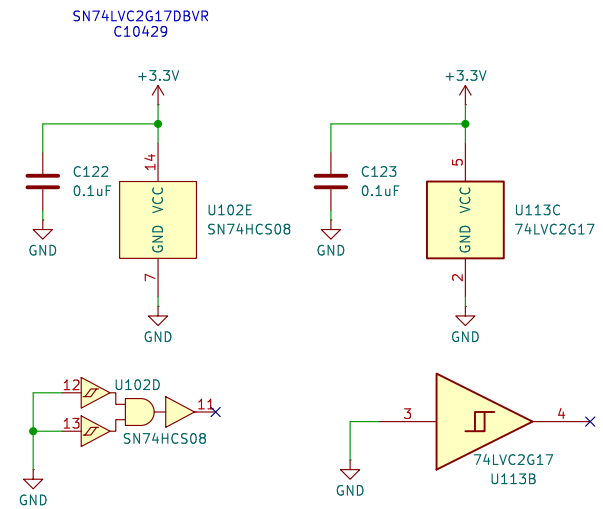
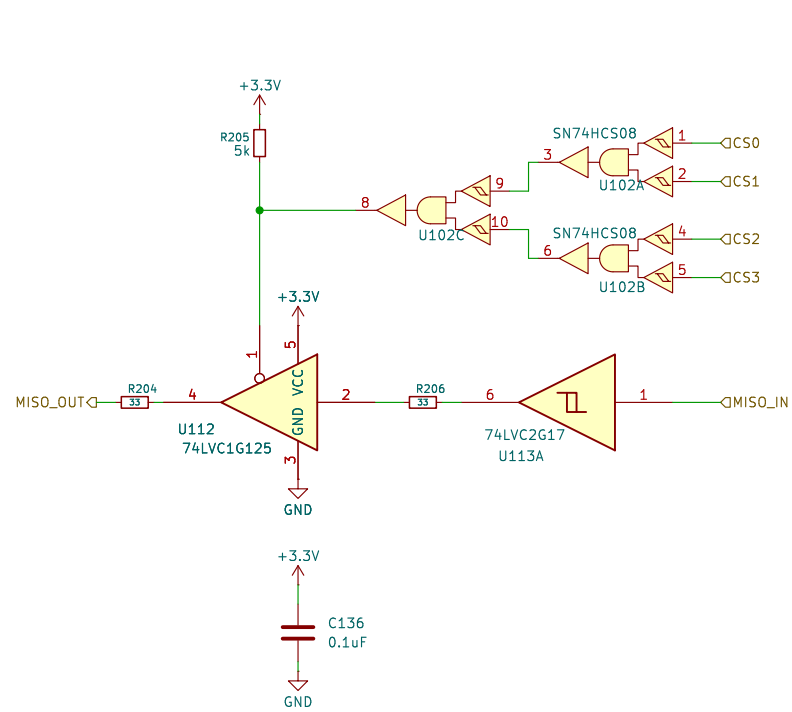

IORodeo for Reiser Lab @ Janelia | HHMI

Sheet: /Fan Out/MISO B1 Enable for P7/
 File: miso_enable.kicad_sch

Title: G6 Teensy 10-10 Arena

Size: A4 Date: 2026-04-27

KiCad E.D.A. 9.0.8

Rev: v1.1.6

Id: 60/63

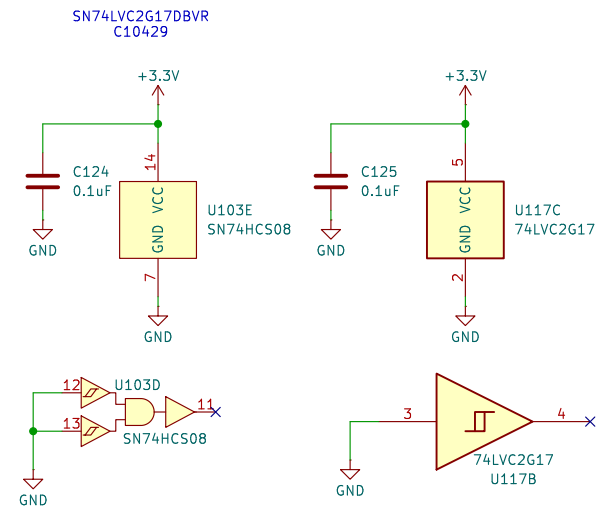
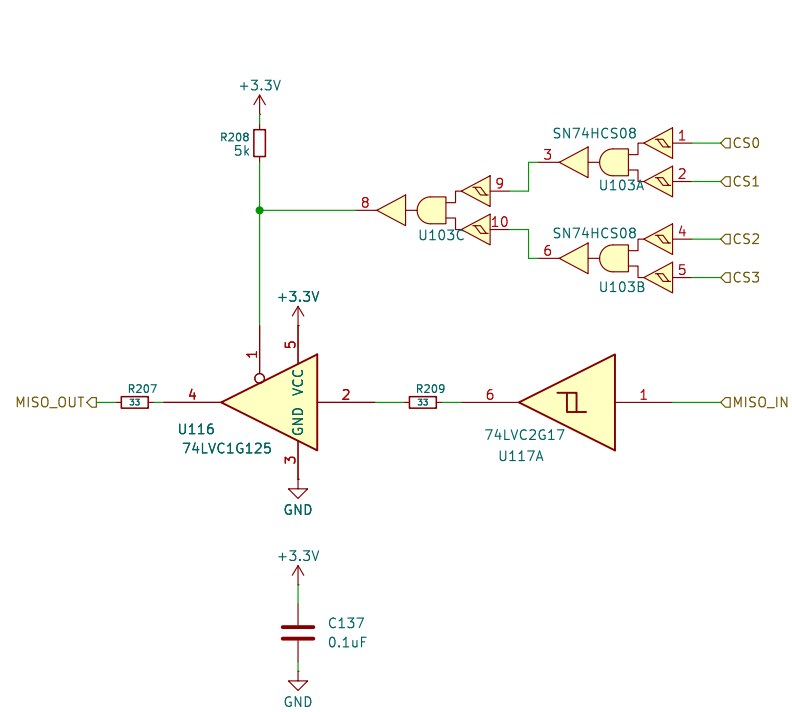

IORodeo for Reiser Lab @ Janelia | HHMI

Sheet: /Fan Out/MISO B1 Enable for P8/
 File: miso_enable.kicad_sch

Title: G6 Teensy 10-10 Arena

Size: A4 Date: 2026-04-27

KiCad E.D.A. 9.0.8

Rev: v1.1.6

Id: 61/63

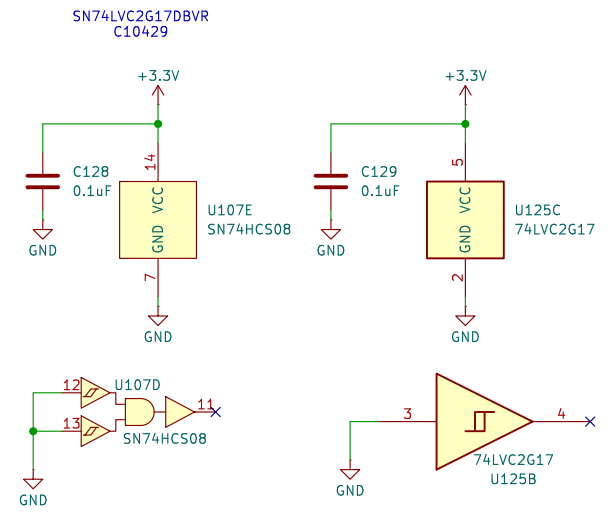
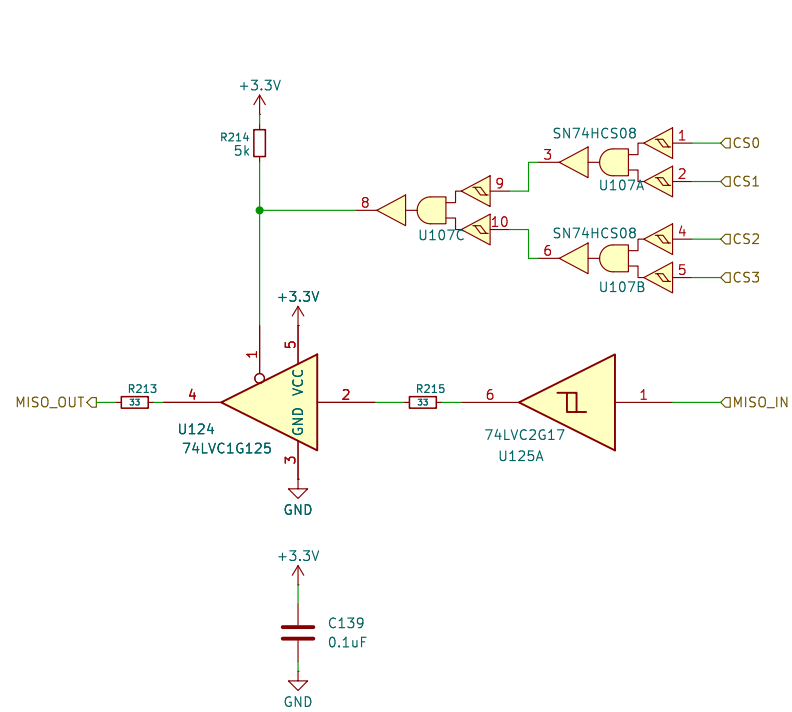

IORodeo for Reiser Lab @ Janelia | HHMI
 Sheet: /Fan Out/MISO B1 Enable for P10/
 File: miso_enable.kicad_sch

Title: G6 Teensy 10-10 Arena

Size: A4	Date: 2026-04-27	Rev: v1.1.6
KiCad E.D.A. 9.0.8		Id: 63/63

Singals to/from Panels

SPI B0 Panel Columns

SPI B1 Panel Columns

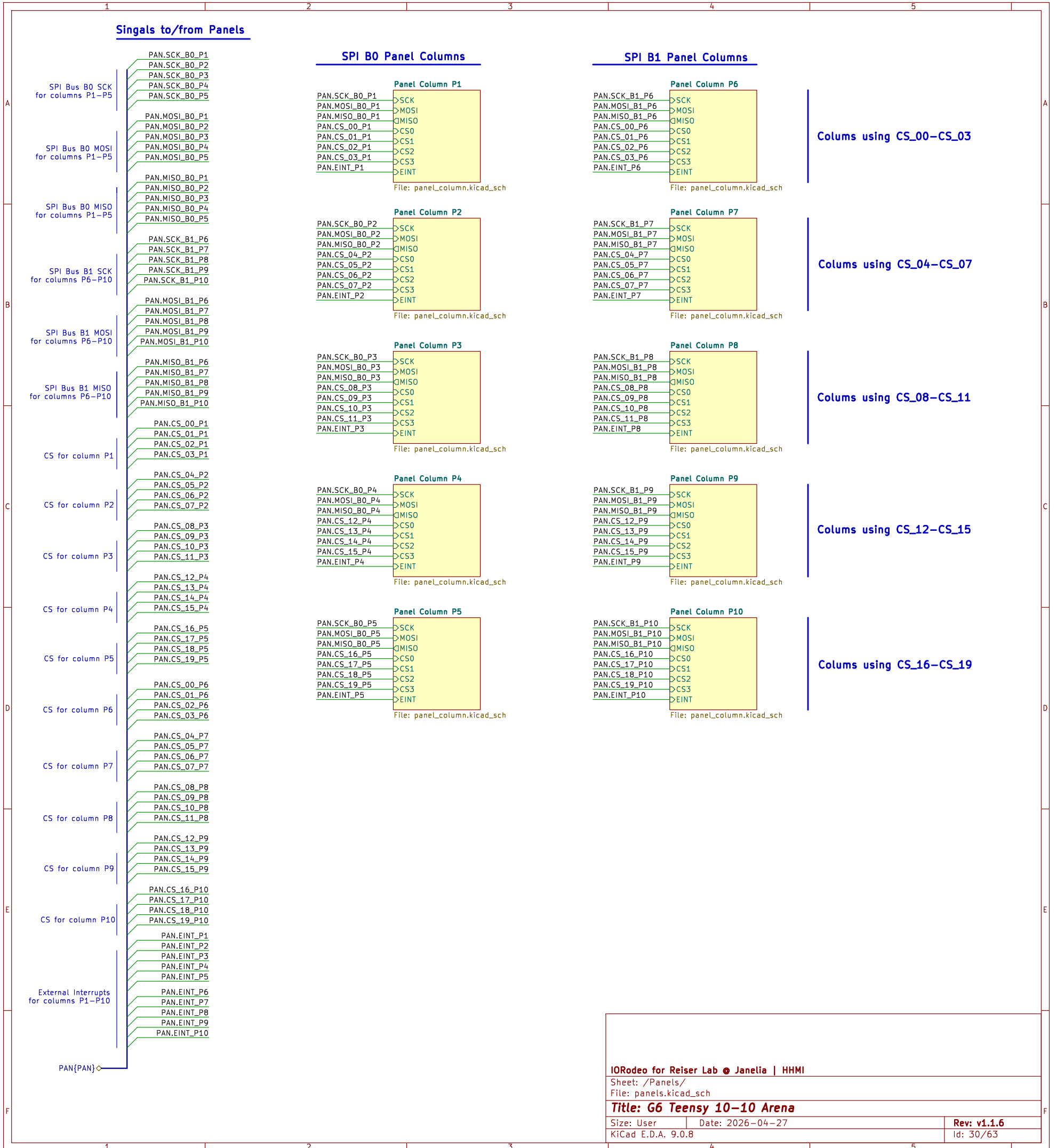

IORodeo for Reiser Lab @ Janelia | HHMI

Sheet: /Panels/
File: panels.kicad_sch

Title: G6 Teensy 10-10 Arena

Size: User Date: 2026-04-27
KiCad E.D.A. 9.0.8

Rev: v1.1.6
Id: 30/63

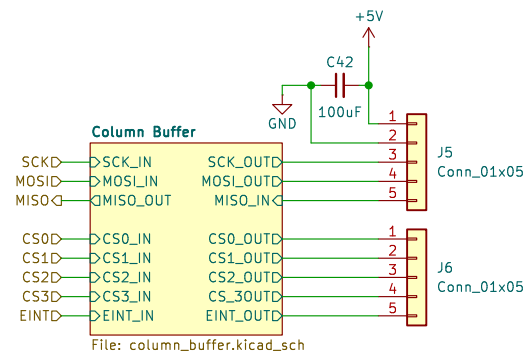

~~Panel Column~~
P1

IORodeo for Reiser Lab @ Janelia | HHMI

Sheet: /Panels/Panel Column P1/

File: panel_column.kicad_sch

Title: G6 Teensy 10-10 Arena

Size: A4 Date: 2026-04-27

Rev: v1.1.6

KiCad E.D.A. 9.0.8

Id: 32/63

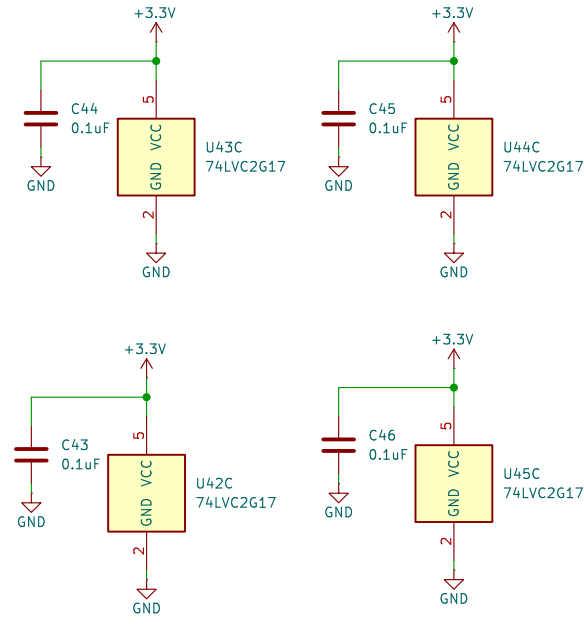
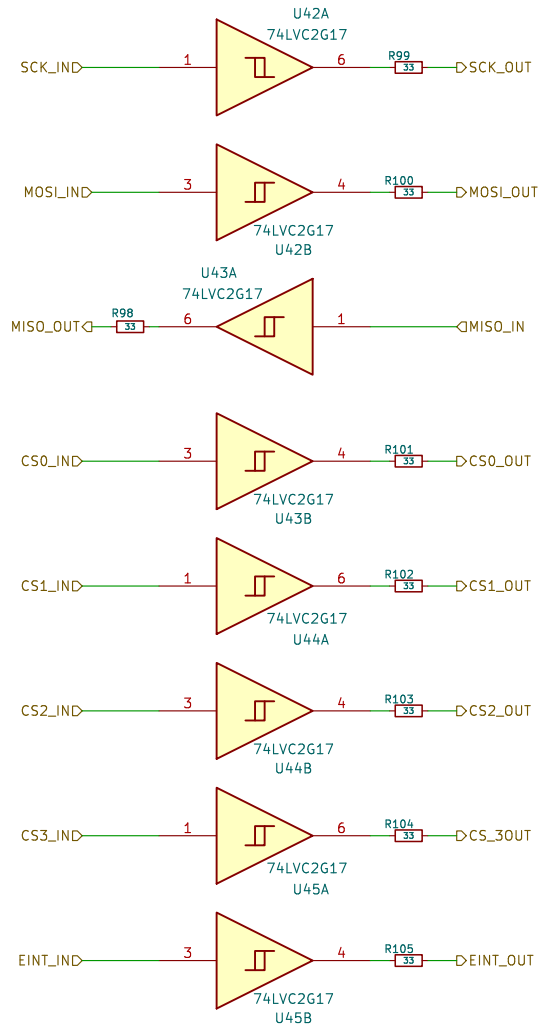

SN74LVC1G125DRLR
296-18012-2-ND

SN74HCS08BQAR
296-SN74HCS08BQARTR-ND

IORodeo for Reiser Lab @ Janelia | HHMI

Sheet: /Panels/Panel Column P1/Column Buffer/
File: column_buffer.kicad_sch

Title: G6 Teensy 10-10 Arena

Size: A4 Date: 2026-04-27

KiCad E.D.A. 9.0.8

Rev: v1.1.6

Id: 31/63

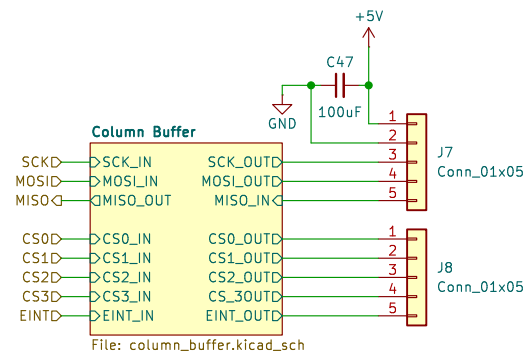

IORodeo for Reiser Lab @ Janelia | HHMI

Sheet: /Panels/Panel Column P2/

File: panel_column.kicad_sch

Title: G6 Teensy 10-10 Arena

Size: A4 Date: 2026-04-27

Rev: v1.1.6

KiCad E.D.A. 9.0.8

Id: 33/63

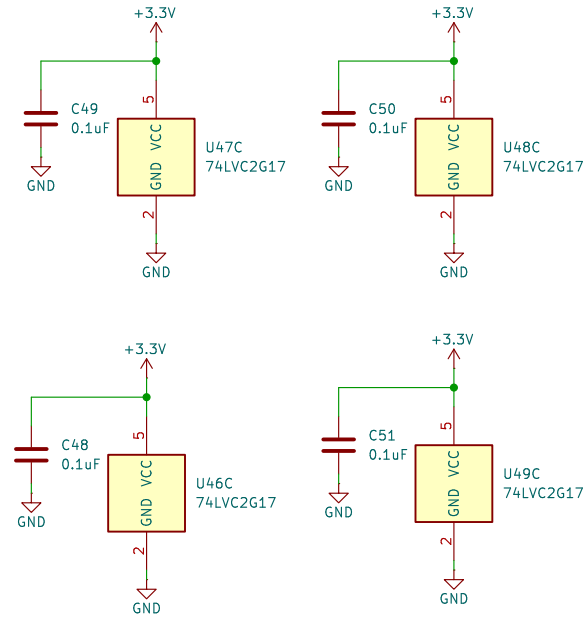
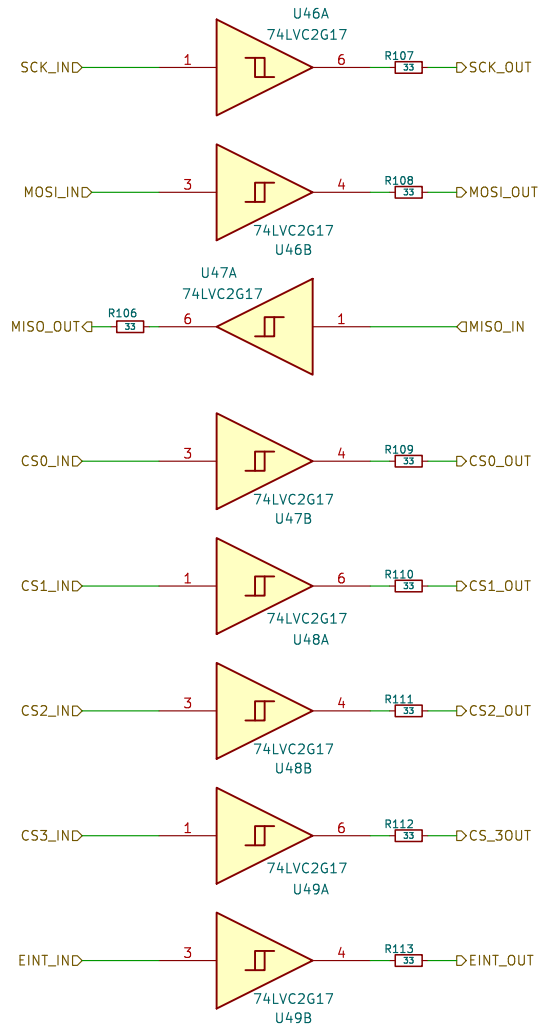

SN74LVC1G125DRLR
296-18012-2-ND

SN74HCS08BQAR
296-SN74HCS08BQARTR-ND

IORodeo for Reiser Lab @ Janelia | HHMI

Sheet: /Panels/Panel Column P2/Column Buffer/
File: column_buffer.kicad_sch

Title: G6 Teensy 10-10 Arena

Size: A4 Date: 2026-04-27

KiCad E.D.A. 9.0.8

Rev: v1.1.6

Id: 34/63

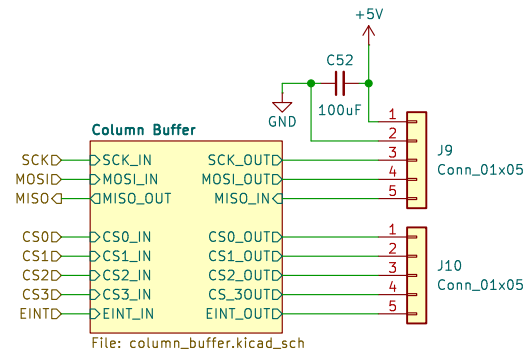

~~Panel Column P3~~
P3

IO Rodeo for Reiser Lab @ Janelia | HHMI

Sheet: /Panels/Panel Column P3/
File: panel_column.kicad_sch

Title: G6 Teensy 10-10 Arena

Size: A4 Date: 2026-04-27

Rev: v1.1.6

KiCad E.D.A. 9.0.8

Id: 35/63

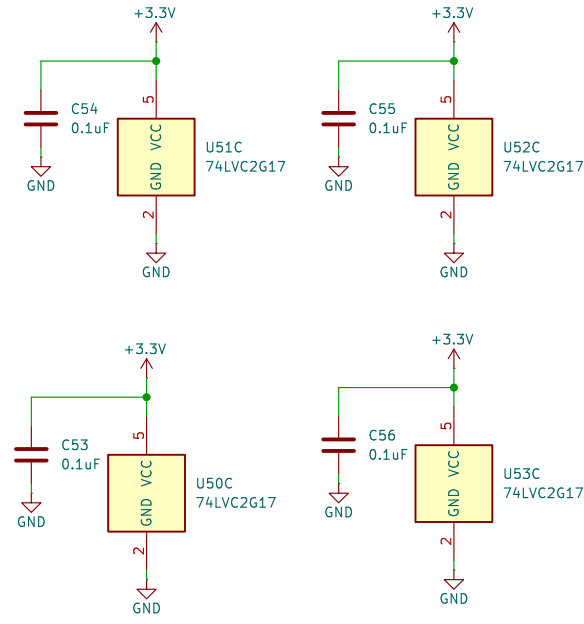
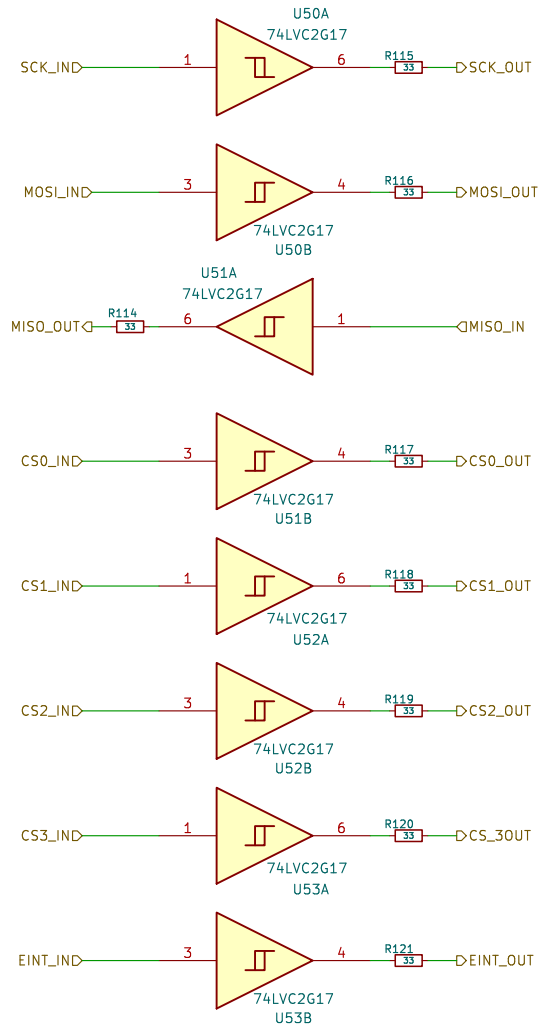

SN74LVC1G125DRLR
296-18012-2-ND

SN74HCS08BQAR
296-SN74HCS08BQARTR-ND

IORodeo for Reiser Lab @ Janelia | HHMI

Sheet: /Panels/Panel Column P3/Column Buffer/
File: column_buffer.kicad_sch

Title: G6 Teensy 10-10 Arena

Size: A4 Date: 2026-04-27

KiCad E.D.A. 9.0.8

Rev: v1.1.6

Id: 36/63

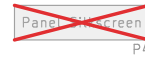
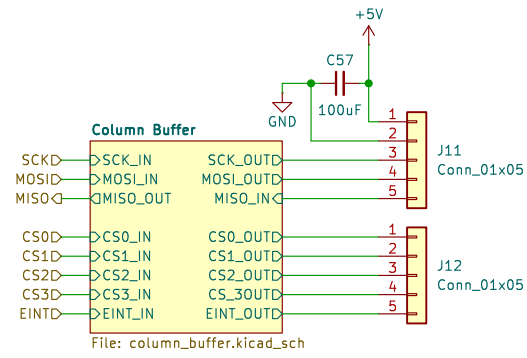

IORodeo for Reiser Lab • Janelia | HHMI

Sheet: /Panels/Panel Column P4/
File: panel_column.kicad_sch

Title: G6 Teensy 10-10 Arena

Size: A4 Date: 2026-04-27

Rev: v1.1.6

KiCad E.D.A. 9.0.8

Id: 37/63

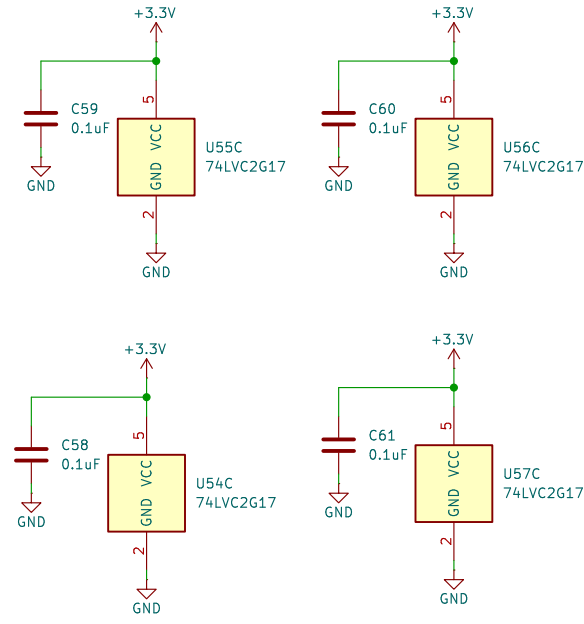
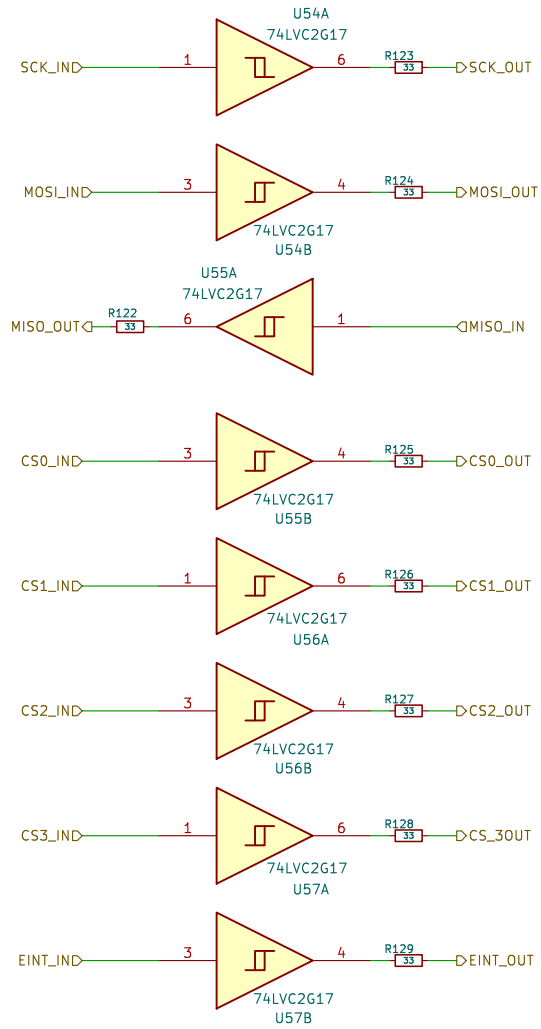

SN74LVC1G125DRLR
296-18012-2-ND

SN74HCS08BQAR
296-SN74HCS08BQARTR-ND

IORodeo for Reiser Lab @ Janelia | HHMI

Sheet: /Panels/Panel Column P4/Column Buffer/
File: column_buffer.kicad_sch

Title: G6 Teensy 10-10 Arena

Size: A4 Date: 2026-04-27

KiCad E.D.A. 9.0.8

Rev: v1.1.6

Id: 38/63

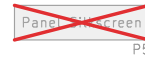
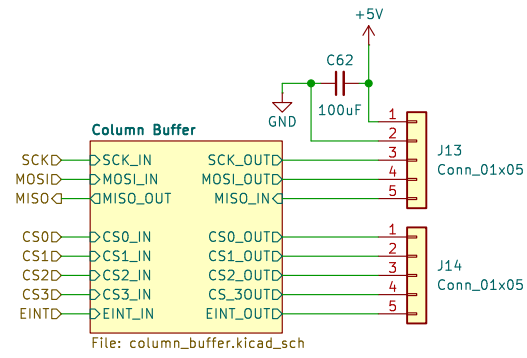

IORodeo for Reiser Lab @ Janelia | HHMI

Sheet: /Panels/Panel Column P5/
File: panel_column.kicad_sch

Title: G6 Teensy 10-10 Arena

Size: A4 Date: 2026-04-27

Rev: v1.1.6

KiCad E.D.A. 9.0.8

Id: 39/63

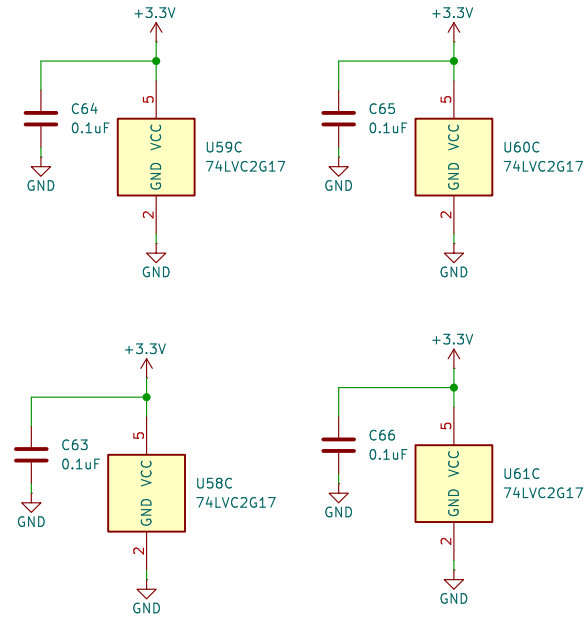
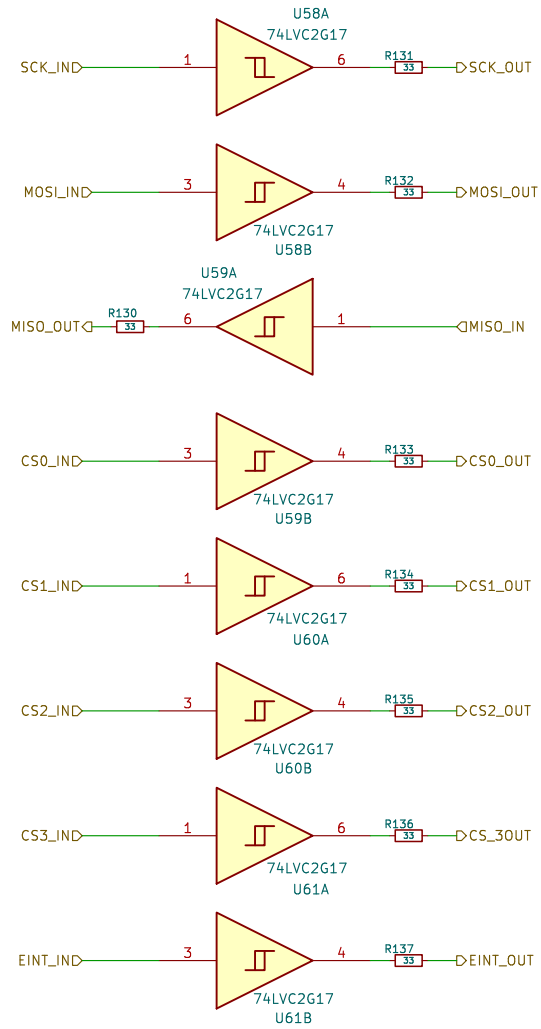

SN74LVC1G125DRLR
296-18012-2-ND

SN74HCS08BQAR
296-SN74HCS08BQARTR-ND

IORodeo for Reiser Lab @ Janelia | HHMI

Sheet: /Panels/Panel Column P5/Column Buffer/
File: column_buffer.kicad_sch

Title: G6 Teensy 10-10 Arena

Size: A4 Date: 2026-04-27

KiCad E.D.A. 9.0.8

Rev: v1.1.6

Id: 40/63

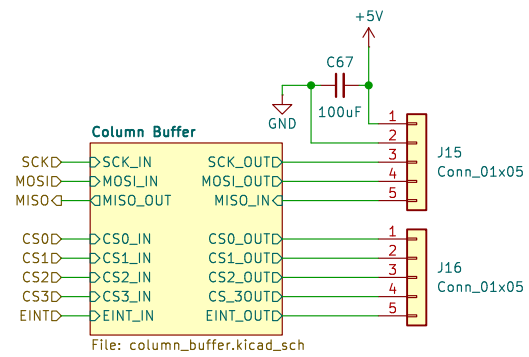

IORodeo for Reiser Lab @ Janelia | HHMI

Sheet: /Panels/Panel Column P6/

File: panel_column.kicad_sch

Title: G6 Teensy 10-10 Arena

Size: A4 Date: 2026-04-27

Rev: v1.1.6

KiCad E.D.A. 9.0.8

Id: 41/63

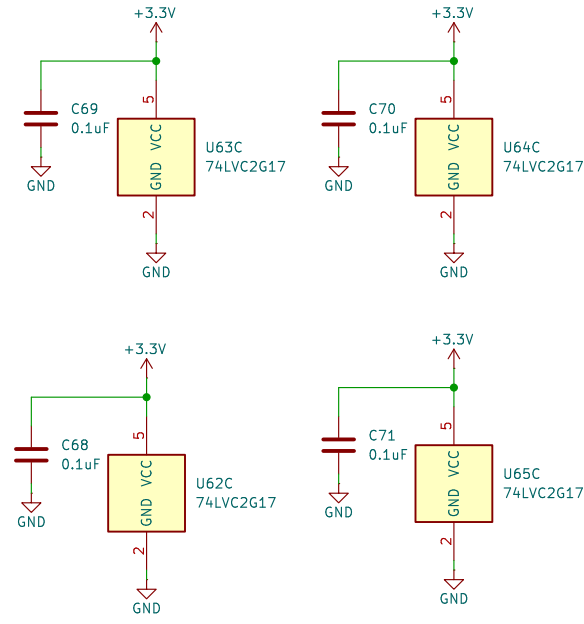
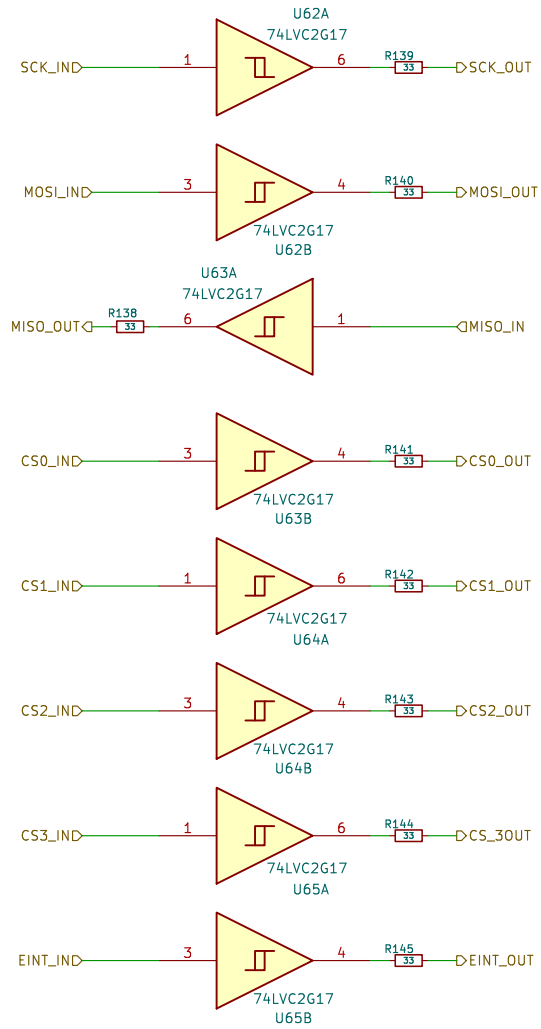

SN74LVC1G125DRLR
296-18012-2-ND

SN74HCS08BQAR
296-SN74HCS08BQARTR-ND

IORodeo for Reiser Lab @ Janelia | HHMI

Sheet: /Panels/Panel Column P6/Column Buffer/
File: column_buffer.kicad_sch

Title: G6 Teensy 10-10 Arena

Size: A4 Date: 2026-04-27

KiCad E.D.A. 9.0.8

Rev: v1.1.6

Id: 42/63

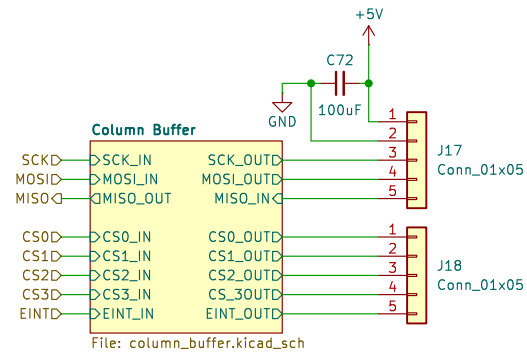

~~Panel Column~~
P7

IORodeo for Reiser Lab • Janelia | HHMI

Sheet: /Panels/Panel Column P7/

File: panel_column.kicad_sch

Title: G6 Teensy 10-10 Arena

Size: A4 Date: 2026-04-27

KiCad E.D.A. 9.0.8

Rev: v1.1.6

Id: 43/63

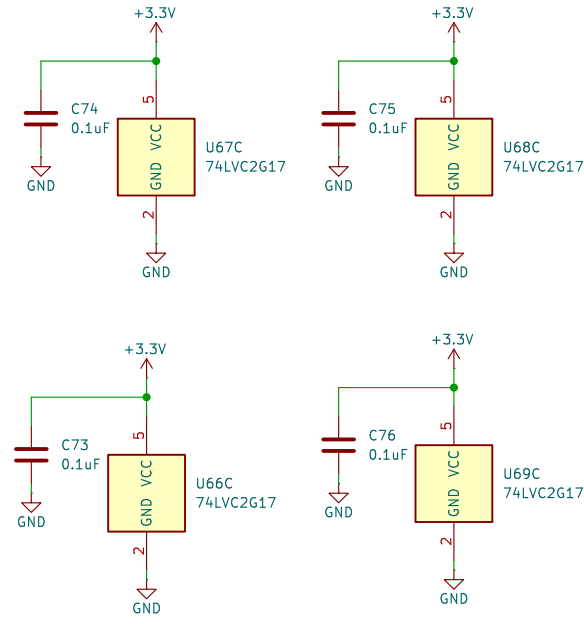
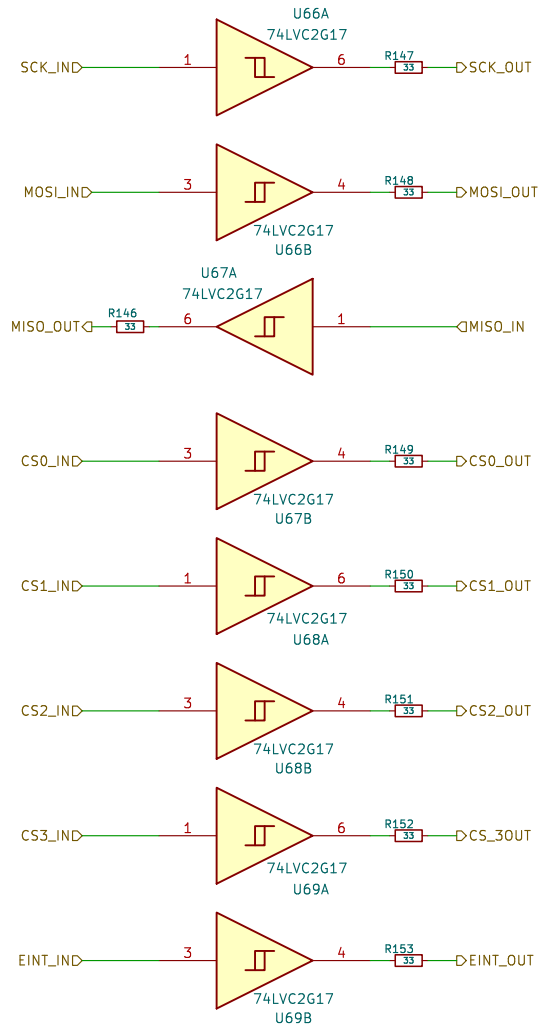

SN74LVC1G125DRLR
296-18012-2-ND

SN74HCS08BQAR
296-SN74HCS08BQARTR-ND

IORodeo for Reiser Lab @ Janelia | HHMI

Sheet: /Panels/Panel Column P7/Column Buffer/
File: column_buffer.kicad_sch

Title: G6 Teensy 10-10 Arena

Size: A4 Date: 2026-04-27

KiCad E.D.A. 9.0.8

Rev: v1.1.6

Id: 44/63

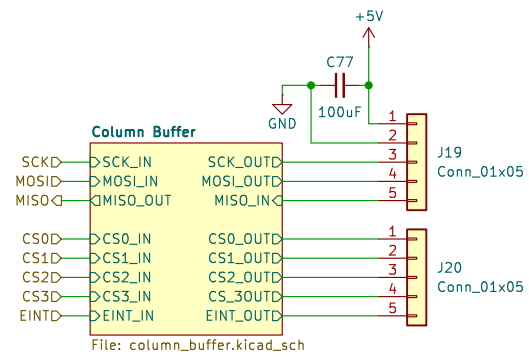

~~Panel Column P8~~
P8

IO Rodeo for Reiser Lab @ Janelia | HHMI

Sheet: /Panels/Panel Column P8/

File: panel_column.kicad_sch

Title: G6 Teensy 10-10 Arena

Size: A4 Date: 2026-04-27

Rev: v1.1.6

KiCad E.D.A. 9.0.8

Id: 45/63

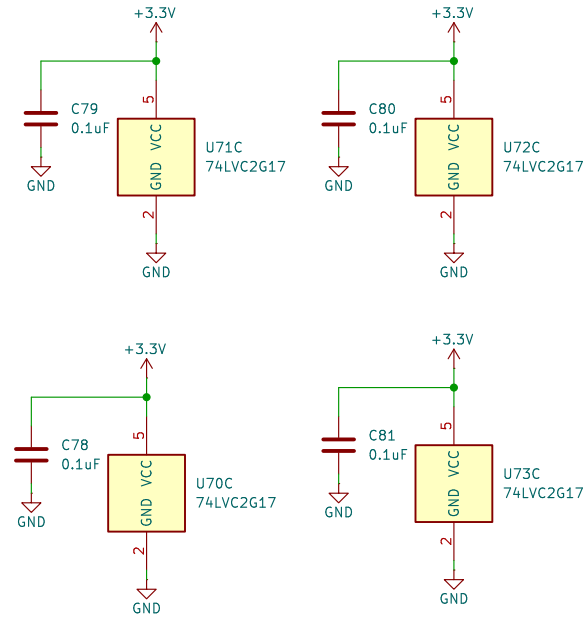
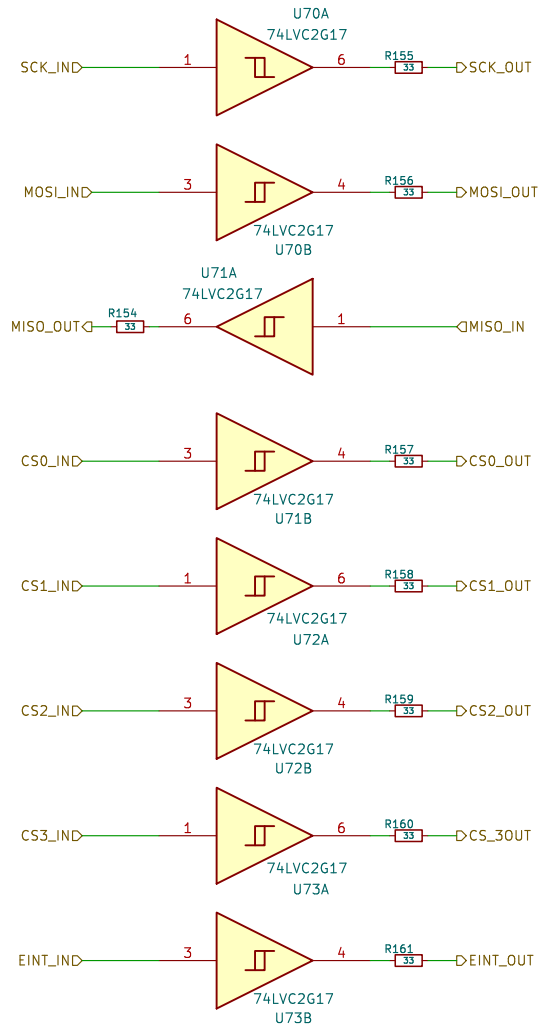

SN74LVC1G125DRLR
296-18012-2-ND

SN74HCS08BQAR
296-SN74HCS08BQARTR-ND

IORodeo for Reiser Lab @ Janelia | HHMI

Sheet: /Panels/Panel Column P8/Column Buffer/
File: column_buffer.kicad_sch

Title: G6 Teensy 10-10 Arena

Size: A4 Date: 2026-04-27

KiCad E.D.A. 9.0.8

Rev: v1.1.6

Id: 46/63

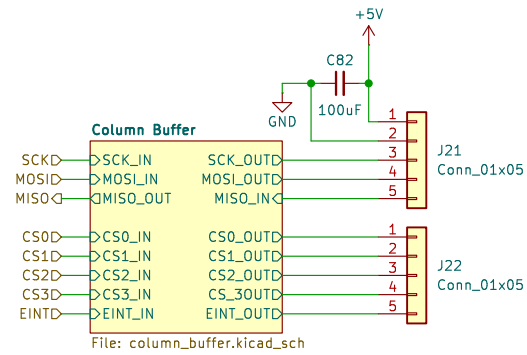

IORodeo for Reiser Lab @ Janelia | HHMI

Sheet: /Panels/Panel Column P9/
 File: panel_column.kicad_sch

Title: G6 Teensy 10-10 Arena

Size: A4 Date: 2026-04-27

Rev: v1.1.6

KiCad E.D.A. 9.0.8

Id: 47/63

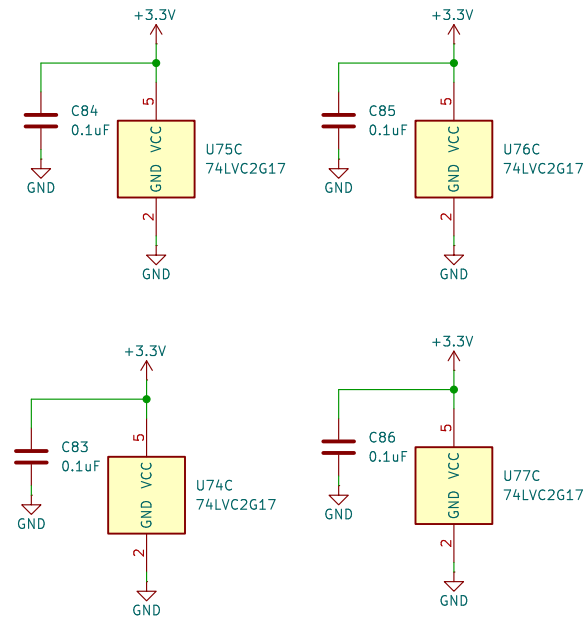
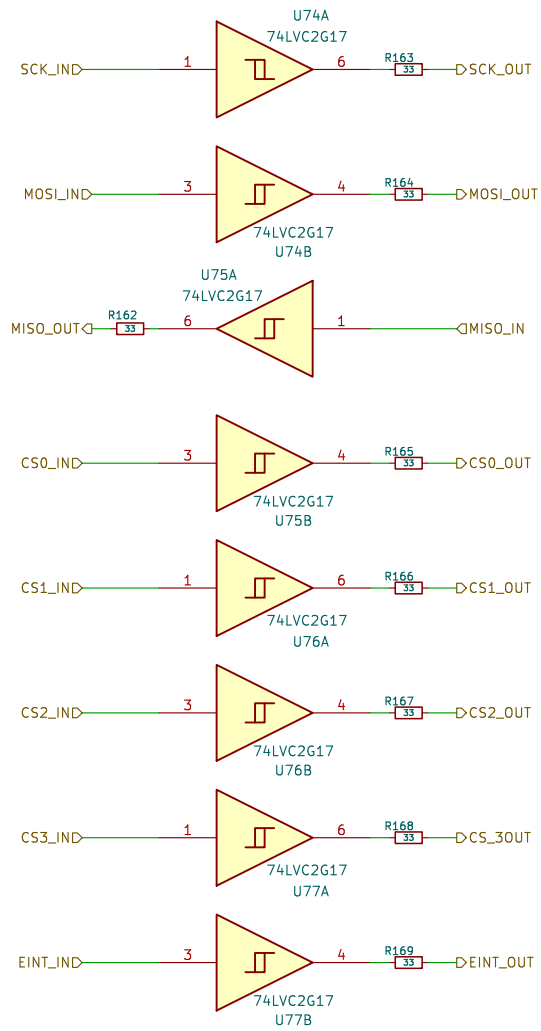

SN74LVC1G125DRLR
296-18012-2-ND

SN74HCS08BQAR
296-SN74HCS08BQARTR-ND

IORodeo for Reiser Lab @ Janelia | HHMI

Sheet: /Panels/Panel Column P9/Column Buffer/
File: column_buffer.kicad_sch

Title: G6 Teensy 10-10 Arena

Size: A4 Date: 2026-04-27
KiCad E.D.A. 9.0.8

Rev: v1.1.6
Id: 48/63

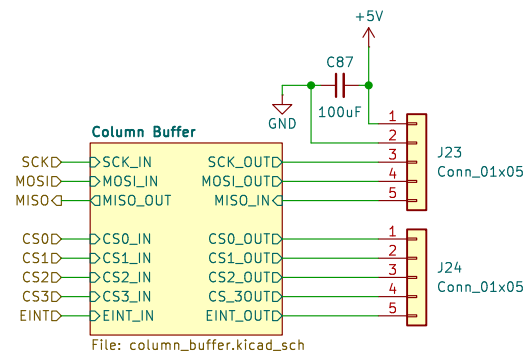

~~Panel Column~~
P10

IORodeo for Reiser Lab @ Janelia | HHMI

Sheet: /Panels/Panel Column P10/
File: panel_column.kicad_sch

Title: G6 Teensy 10-10 Arena

Size: A4 Date: 2026-04-27

KiCad E.D.A. 9.0.8

Rev: v1.1.6

Id: 49/63

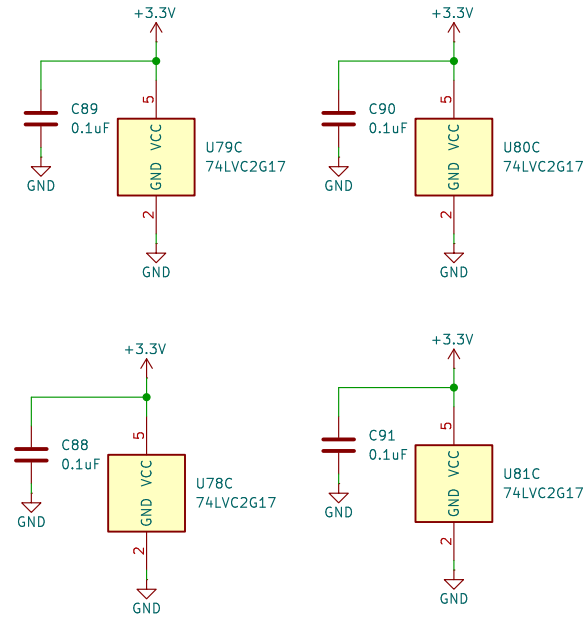
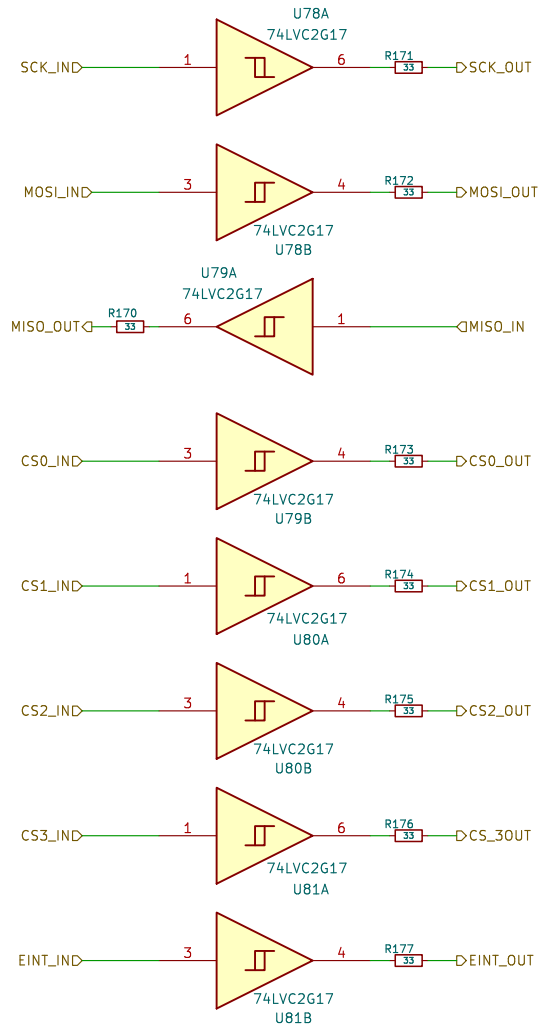

SN74LVC1G125DRLR
296-18012-2-ND

SN74HCS08BQAR
296-SN74HCS08BQARTR-ND

IORodeo for Reiser Lab @ Janelia | HHMI

Sheet: /Panels/Panel Column P10/Column Buffer/
File: column_buffer.kicad_sch

Title: G6 Teensy 10-10 Arena

Size: A4 Date: 2026-04-27

KiCad E.D.A. 9.0.8

Rev: v1.1.6

Id: 50/63

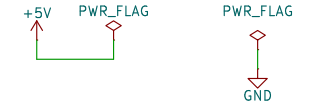
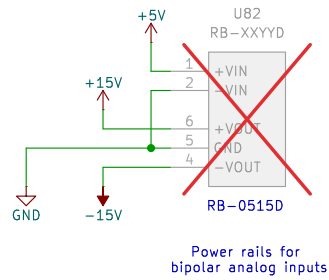
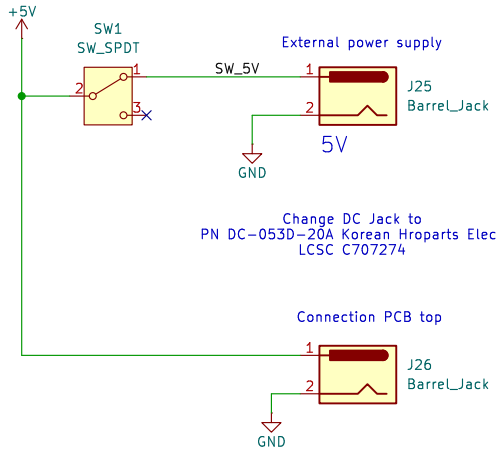

IORodeo for Reiser Lab • Janelia | HHMI

Sheet: /Power/
File: power.kicad_sch

Title: G6 Teensy 10-10 Arena

Size: A4 Date: 2026-04-27

KiCad E.D.A. 9.0.8

Rev: v1.1.6

Id: 51/63

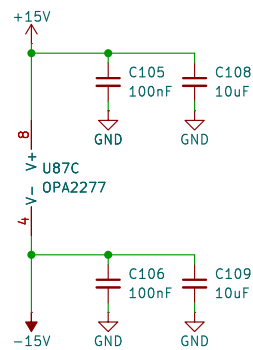
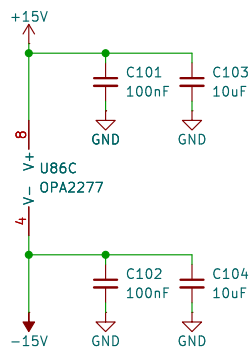
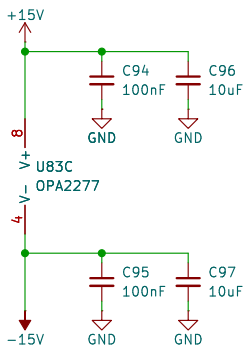
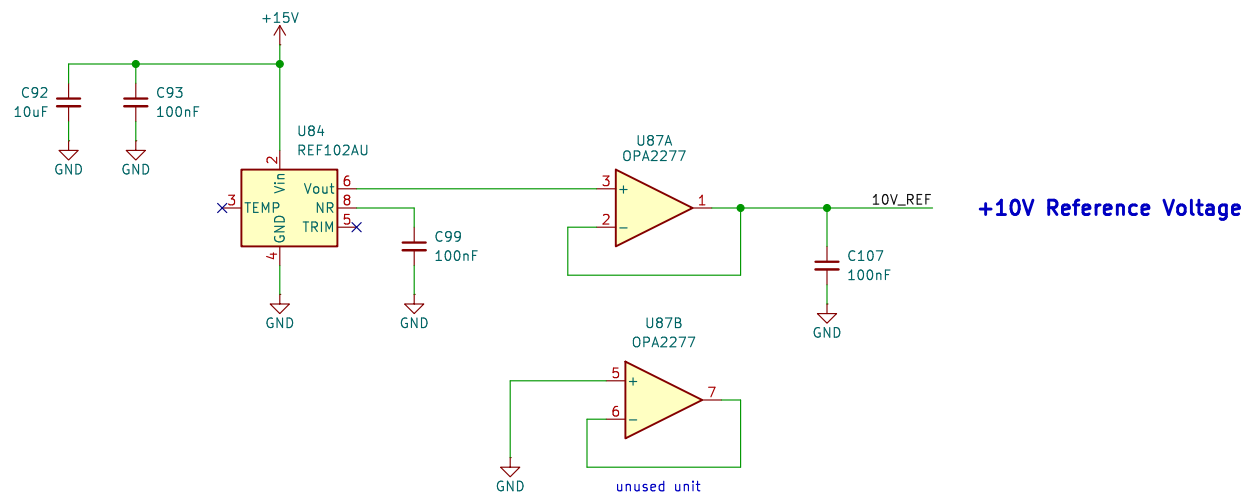
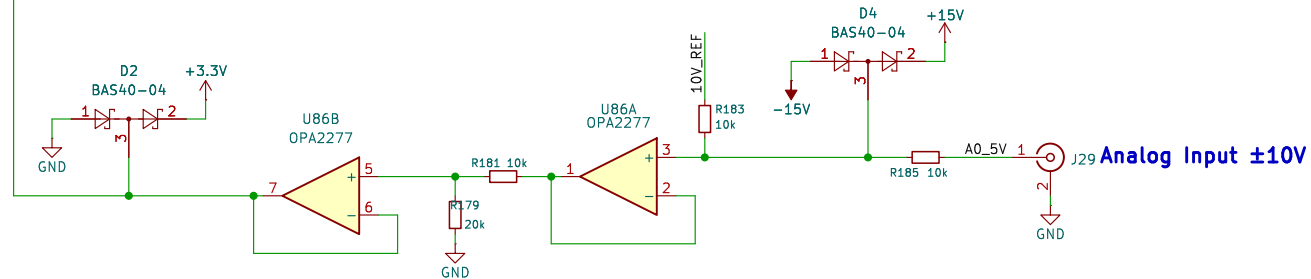
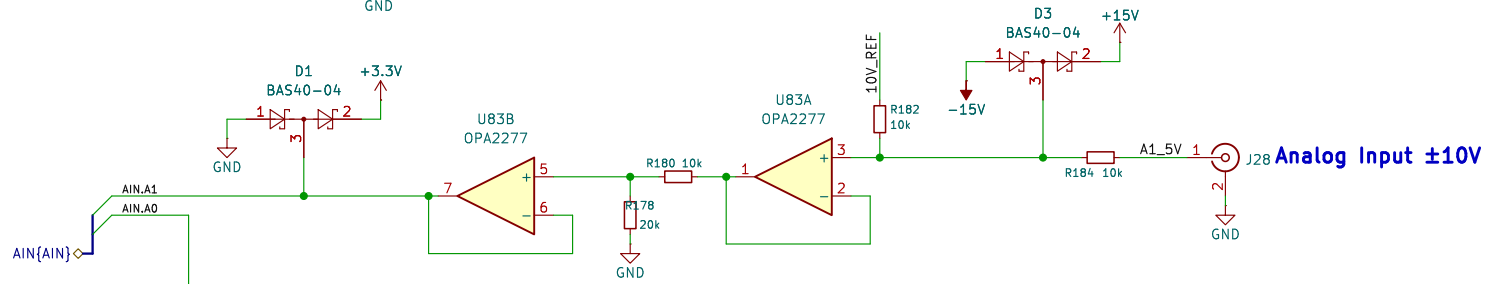
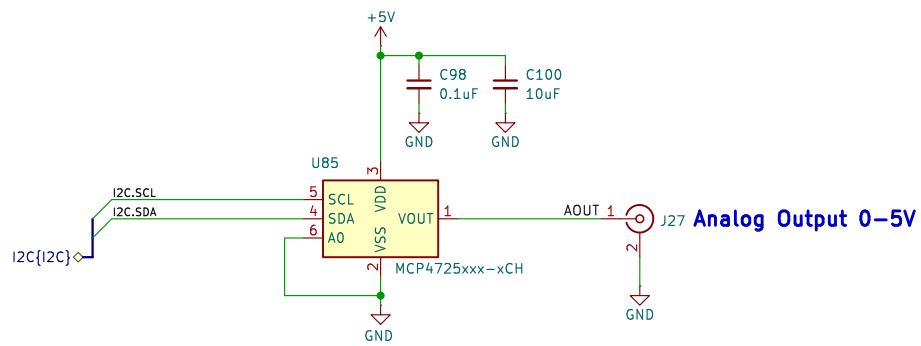

IORodeo for Reiser Lab © Janelia | HHMI

Sheet: /Analog IO/
File: analog.kicad_sch

Title: G6 Teensy 10-10 Arena

Size: User Date: 2026-04-27
KiCad E.D.A. 9.0.8

Rev: v1.1.6
Id: 52/63

